



# Port Hawkesbury Paper LP Sustainable Long-Term Forest Management Plan for FULA Lands

---



© Tree Top Images

*December 2022*

# ABOUT PORT HAWKESBURY PAPER

Port Hawkesbury Paper is a forward-looking natural resources company committed to operating at the highest safety standard while caring for the environment and empowering our people to deliver top-quality products & customer service. We see integrity at the core of every relationship and a key principle as we strive for excellence in all we do in an ever-changing world. As a relatively small non-hierarchical organization we deliver big results. We are a leader in Thermal Mechanical Pulp and Supercalendered paper production in North America. Port Hawkesbury Paper’s approach to business and environmental sustainability creates an economic cornerstone for eastern Nova Scotia.

Port Hawkesbury Paper ships its products to customers throughout North America and worldwide. The mill produces the Artisan® (SCA++) and Prominence® Plus (SCA+) brands for use in retail inserts, catalogs, magazines, circulars, coupons, and specialty packaging applications.

Since 2001, the mill has maintained forest management certification and is currently certified to the forest management standards of the Forest Stewardship Council® (FSC®; FSC®C023189) and Sustainable Forestry Initiative® (SFI®).

The company is also independently certified to the chain of custody standards of FSC (FSC-C112699), SFI, and the Programme for the Endorsement of Forest Certification (PEFC). These standards ensure that the company meets all requirements for the management of ecological, social, and economic forest values. Chain of custody certification also verifies that company paper bearing an FSC, SFI, or PEFC label comes from well-managed forests or controlled sources.



**Submitted on Behalf of Port Hawkesbury Paper, Woodlands, for:**

Bevan Lock, Mill Co-Manager

Dennis Boulet, Woodlands Manager

Rod Higgins, Superintendent Forest Resources

A handwritten signature in blue ink that reads "Andrea Doucette". The signature is written in a cursive style with a large initial 'A'.

Andrea Doucette, Superintendent Certification Environment Outreach

December 8, 2022

<b>1</b>	<b>INTRODUCTION.....</b>	<b>8</b>
1.1	Purpose .....	8
1.2	Planning Background & Requirements.....	8
1.3	Scope of Timber Supply Analysis .....	9
1.4	Analysis Timeline .....	10
<b>2</b>	<b>PORT HAWKEBURY PAPER LP .....</b>	<b>11</b>
2.1	Mill History .....	11
2.2	Forest Utilisation License Agreement (FULA).....	11
2.3	Forest Management Planning .....	12
2.4	Silviculture.....	13
2.5	Rights and Regulations .....	14
2.6	Legislation and Regulatory Requirements.....	14
2.7	Forest Workers in Defined Forest Area .....	14
<b>3</b>	<b>LAND-BASE DESCRIPTION .....</b>	<b>14</b>
3.1	Land-base Netdown Process .....	16
<b>4</b>	<b>ECOLOGICAL LAND-BASE DESCRIPTION .....</b>	<b>19</b>
4.1	Ecoregions .....	19
4.2	Ecodistricts .....	20
4.3	Forest Elements .....	21
<b>5</b>	<b>FSC DEFINED PLANTATIONS .....</b>	<b>22</b>
<b>6</b>	<b>FOREST COMMUNITIES .....</b>	<b>24</b>
<b>7</b>	<b>PUBLIC OUTREACH .....</b>	<b>26</b>
7.1	Forest Advisory Committee.....	26
7.2	General Stakeholder Engagement.....	26
7.3	High Conservation Value Forests .....	26
7.4	Aboriginal and Treaty Rights.....	27
<b>8</b>	<b>Monitoring.....</b>	<b>30</b>
8.1	Environmental & Safety Management.....	30
8.2	Monitoring Program .....	30

8.3	Internal Audits .....	31
8.4	External Audits .....	31
8.5	Linkages between Long-term Plan and Annual Operating Plans.....	31
9	FOREST CERTIFICATION .....	33
10	WILDLIFE POLICY .....	34
10.1	American Marten .....	34
10.2	Mainland Moose .....	36
10.3	Deer Wintering Areas .....	37
10.4	Boreal Felt Lichen .....	38
11	LANDSCAPE LEVEL MANAGEMENT .....	39
11.1	Natural Disturbance Regimes .....	39
11.2	Integrated Pest Management.....	40
12	STRATEGIC CONSIDERATIONS AND ADJUSTMENTS.....	40
13	AGE CLASS DISTRIBUTION .....	41
14	ECOLOGICAL-BASED MANAGEMENT .....	43
15	References .....	44
Appendix I	PHP Sustainable Forest Management Policy .....	46
Appendix II	Environmental Policy - Woodlands.....	51
Appendix III	Bio-Indicator Species.....	52
	Barred Owl ( <i>Strix varia</i> ).....	52
	White-winged Crossbill ( <i>Loxia leucoptera</i> ) .....	53
	Black-backed Woodpecker ( <i>Picoides articus</i> ) .....	53
	Bicknell’s Thrush ( <i>Catharus bicknelli</i> ) .....	55
	Pileated Woodpecker ( <i>Dryocopus pileatus</i> ).....	56

## ***Disclaimer Statement***

As stipulated in the Forest Utilization License Renewable Agreement (FULA) with the province of Nova Scotia signed in February 2023, “the Long-term Forest Plan is the Sustainable Forest Management Long-term Forest Plan as prepared by PHP and as approved by the province on January 2015, excepting for the harvest volume level”.

In 2021, PHP began a joint timber supply analysis with the Forestry Division of the NS Department of Natural Resources & Renewables as an update to the analysis completed in 2015. This analysis was conducted to support the new FULA as the province transitions to a triad forest management system for Crown lands as recommended in the report “An Independent Review of Forest Practices in Nova Scotia” (2018). At the time of the timber supply analysis in 2021, certain components, policies and guidelines related to the ecological matrix and high production forest areas of the triad framework were not fully developed or finalized.

As the province is now closer to the full implementation of the triad management framework on Crown lands through a forest stewardship planning process, PHP will begin a new and full long-term planning process that meets this new approach beginning in 2023. A new and fully updated strategic plan that incorporates triad management will be developed by December 31, 2026.

## ***Executive Summary***

This document outlines Port Hawkesbury Paper's 2022 Sustainable Forest Management Long-term Plan (SFMLTP) for its forest management area (FMA) in Eastern Nova Scotia, Canada. The forest modelling component was implemented as a joint project between Port Hawkesbury Paper (PHP) and the Nova Scotia Department of Natural Resources and Renewables (NSDNRR) for the calculation of an updated annual allowable cut (AAC). The AAC under this plan is calculated at 275,000 green metric tonnes per year.

This plan covers a 100-year planning horizon (2021 – 2121) as the company transitions to a new triad approach for forest management as outlined in *An Independent Review of Forest Practices in Nova Scotia (Lahey, 2018)*. As such, this plan can be considered an interim plan as PHP fully transitions to triad management over the next few years and will be replaced by a new plan by year-end 2026.

This Plan adheres to the principles of adaptive forest management and continual improvement. The Plan was completed on the foundation of ecological landscape planning, natural disturbance regimes, and sustainable forest management principles. Furthermore, it conforms to the company's commitment and statements to environmental and social responsibility.



# 1 INTRODUCTION

## 1.1 Purpose

The purpose of this Sustainable Forest Management Long-term Plan is to define the objectives, goals, commitments, and strategies for the PHP Crown license area over a 100-year planning horizon (2022 to 2122). This plan aims to satisfy the requirements of the Nova Scotia Department of Natural Resources & Renewables (NSDNRR) and the recently renegotiated 10-year Forest Utilization License Agreement (FULA) with the province of Nova Scotia for Crown land management.

For the eastern Crown license area, PHP and NSDNRR began a cooperative wood supply analysis project in 2021 to replace the wood supply analysis completed for the 2015 plan. The goal of the study was to establish an updated sustainable harvest level that took new forest management guidelines from the 2018 Forestry Review (FR) process into account as well as support the renegotiation of the FULA agreement which expired in late 2022. The new FULA license agreement beginning in 2023 requires PHP to submit a full and complete plan that conforms to the new forest management paradigm by December 31, 2026, and every 5 years thereafter.

The company has been certified to the Forest Stewardship Council® (FSC®) standard since 2008 and Sustainable Forestry Initiative® (SFI®) standard since 2014. PHP is committed to maintaining these certifications and this plan aims to align the company's vision, values, and strategic and operational management objectives with the requirements of both standards.

## 1.2 Planning Background & Requirements

One of the key methods used in Canada to guarantee that the nation's publicly owned forests are managed responsibly and to maintain their health and vitality is forest management planning. The forest management plan, which every forest company is required by law to create and have authorised by the government before any harvesting can start on public lands, is essential to this strategy ([www.nrcan.gc.ca](http://www.nrcan.gc.ca)).

A forest management plan, which often covers a number of decades, should:

- Describe a strategy plan and commitment to safeguarding various forest values in the managed region.
- Identify the management objectives, describe the desired future state of the forest values in the area, and evaluate the actual condition of the forest in the area to which the plan is applied.
- Outline the harvesting, regeneration, and other operations that will be done to accomplish the given goals within a sustainable annual allowable cut or timber supply analysis ([www.nrcan.gc.ca](http://www.nrcan.gc.ca)).



This 100-year management plan is a legal requirement of PHP's Forest Utilization License Agreement with the province of Nova Scotia. The plan is submitted by PHP (the licensee) to the provincial government for approval by NSDNRR. The 100-year plan is updated every five years and submitted to the government for review and approval.

In addition to this strategic long-term forest management plan, PHP develops more intricate tactical plans for operating regions to direct, for example, road construction and harvest schedules. Additionally, PHP's annual operating plans specify the precise locations and timing of harvesting operations and regeneration activities for a given year. These tactical plans are created for a rolling five-year period and are posted to the provincial government's harvest viewer website for public comment.

### 1.3 Scope of Timber Supply Analysis

To support the renegotiation of the FULA, which expired in late 2022, the analysis began in early 2021 to determine an updated sustainable harvest level for PHP FULA lands. New forest management strategies were created in response to the 2018 forest review process, and these strategies eventually affect the sustainable harvest level. Currently, new policies and requirements for implementing a new approach to forest management are under development, so the work undertaken in 2021 used the best available information at that time.

The idea of TRIAD forest management, which consists of three separate zones: Protected, Ecological Matrix (EM), and High Production Forestry (HPF), is a key component of the new strategy. The protected zone for this analysis is the current status of existing and proposed protected areas. The analysis considers various zoning scenarios since the EM and HPF zones have not yet been established. The guidance from the December 2020 Draft Silvicultural Guide for the Ecological Matrix served as the basis for the EM management techniques (SGEM). The High Production Forestry Phase 1 - Discussion Paper from February 2020 served as the basis for the HPF assumptions.

Given this, the analysis method used interim guidance where available, and any results must be interpreted with consideration for the inherent uncertainty. The existing FULA agreement and FSC certification standards that PHP adheres to were integrated with the new management policies.

The following analysis team consisted of members of NSDNRR and PHP, as well as a consultant from Remsoft:

Joel Taylor, Superintendent of Forest Resources, PHP

Kari Easthouse, Director of Client Services, Remsoft

Rob O'Keefe, Supervisor Resource Analyst, NSDNRR

James Steenberg, Resource Analyst, NSDNRR

Mark Hudson, Resource Analyst, NSDNRR

Jamie Ring, Resource Analyst, NSDNRR

## 1.4 Analysis Timeline

The below table provides an overview of work completed by the analysis team.

Table 1. Analysis Timeline Overview

Month	Task
December 2020	Update Land-base
	Develop analysis Plan
January 2021	Finalize model assumptions
	Finalize Land-base
February 2021	Create Base model
	Finalize Outputs
March 2021	Running scenarios
	New Base Model v2
April 2021	Running scenarios
	New Base Model v3, v4
May 2021	Finalizing A Preferred Scenario
	New Base Model v5
June 2021	Final Base Model v6
	Summary Report
	Finalizing Results
July-Sept 2021	Finalize Report

## 2 PORT HAWKEBURY PAPER LP

### 2.1 Mill History

The Mill site owned by Port Hawkesbury Paper LP has been a fundamental component of the provincial and local economy for over 50 years. The original site was developed by Nova Scotia Pulp Limited which opened the sulphite market pulp mill in 1962. In 1971, the PM-1 newsprint machine was finished, capable of producing 190,000 mt/yr. Over the course of 20 years (1960 to 1980) Port Hawkesbury's population more than doubled; significantly influenced by job-growth provided by the mill.

In 1998, PM 2 super-calendar paper machine (SC-A++) was completed and brought into use, capable of producing 360,000 mt/yr. In 2004, StoraEnso completed the expansion of the super-calendar line with the addition of TMP (Thermo Mechanical Pulp) on Line 3. In 2007 the mill was purchased by NewPage Corporation. In 2008 the Woodlands Unit achieved FSC (Forest Management and Chain of Custody) certifications. In 2011, the hog boiler and 60MW steam turbine project were sold to NSPI. In 2012 the mill was purchased by Port Hawkesbury Paper LP at which point all resources were devoted to producing paper on the super-calendar machine. The mill directly employs over 300 people and provides an additional 400-500 jobs for woodlands contractors and suppliers.

Port Hawkesbury Paper LP is looking towards the future with exciting new projects and efficiency improvements to reduce the energy requirements of the Mill. Port Hawkesbury Paper LP with the backing of the provincial government, and sound new investments is poised to continue being a significant contributor to the provincial economy for many years to come.

### 2.2 Forest Utilisation License Agreement (FULA)

PHP entered into a Forest Utilization License Agreement (FULA) with the province of Nova Scotia in 2012. The length of the agreement is 20 years with renewal after the first 10 years. The FULA replaces the original 1969 Crown licence agreement held by the original mill owner. Under the provisions of the license agreement, the Province of Nova Scotia grants the company the right and responsibility to conduct all forestry activities in accordance with approved forest management plans. "Forestry activities", when used in relation to the agreement lands, means, but is not limited to, the activities of management, planning, wood supply analysis, coordination, certification, harvesting, transporting, silviculture and the construction, maintenance and decommissioning of access roads. "Forest management plan(s)" means collectively the long-term forest plans and the annual operating plans and any other forest management plan(s) as agreed to.

## 2.3 Forest Management Planning

Under the Forest Utilization Licence Agreement, PHP is responsible for the development of all forest management plans on licensed Crown lands. The long-term and annual operating plans must be reviewed and approved by the NSDNRR before implementation. Specific requirements regarding forest planning are articulated below as excerpts from the 2022 FULA (section 17):

### 17.1 Long-Term Forest Plan

*The Long-term Forest Plan is the Sustainable Forest Management Long-term Forest Plan as prepared by PHP and as approved by the Province on January, 2015, excepting for the harvest volume level addressed below.*

### 17.2 Subsequent Long-Term Forest Plans

*Subsequent long-term forest plans shall be submitted for approval on or before December 31, 2026 and every five (5) years thereafter.*

*A Long-term Forest Plan shall be composed of two parts as follows:*

- (i) the planning horizon for a non-declining supply of Primary Forest Products by major category (such as Softwood Pulpwood; Softwood Sawlog and studwood; Hardwood Sawlog; Biomass Feedstock and firewood) will be for a minimum of one hundred years and shall incorporate PHP objectives and the Province's forest resource and land use objectives. The Province and the PHP shall develop the Long-term Forest Plans, jointly, sharing information and data in a cooperative and collaborative manner and, in particular, shall jointly undertake wood supply analyses using mutually agreeable methodologies, applicable/available growth and yield data and science, extensive ground level information to inform realistic estimates of forest harvesting, and restriction deductions resulting from various forest resource and land use policies. The Province will specify long-term goals, objectives and policies for sustaining a range of forest values and where possible, resource restrictions affecting wood supply will be "stacked" on the same land base to lessen impacts on potential wood supply. Protected areas will be examined to ascertain what they contribute to policy directives; and*
- (ii) a twenty (20) year spatial and temporal plan by NRR Ecological Planning Units ("EPU"), or other such approach as may be mutually developed over time, which shall directly support the long-term planning horizon of 100 years. For each NRR EPU, a plan will be developed showing, but not limited to, the following in accordance with policy: unique areas, protected areas, old forest, sensitive habitats, wetlands and watercourses, wildlife connectivity corridors, major harvest blocks and main access roads. A twenty (20) year schedule of forest activity by harvest and Silviculture treatment will be developed, based on the results of landscape level spatial planning activities, for each ecodistrict. The treatments selected shall be those that best promote biodiversity as well as growth and yield on an ecosystem management basis.*

### 17.3 Annual Operating Plans

PHP shall prepare and submit to the Province for approval by October 31 in each Operating Year an updated Annual Operations Plan for the following Operating Year showing:

- (i) *the areas of planned forest operations for a minimum period of three Operating Years;*
- (ii) *all planned road construction during that three-year period;*
- (iii) *the Silviculture Plan for the upcoming year with an estimate of total cost; and*
- (iv) *Silviculture Services' funding requirement by treatment category for the following year as per provisions of this Agreement.*

Although the Agreement constitutes a legally binding commitment, the provincial government, as owner and manager of all resources within the Crown license area, continues to play a significant role in resource management. Provincial legislation, regulations and policies still govern:

- Indigenous Rights
- Protection of forests from natural disturbances such as fire and insect infestation.
- Mineral and petroleum rights.
- Management and control of land on inland and coastal shorelines lying below ordinary mean high-water mark.
- Control and management of wildlife related activities (hunting, fishing, and endangered species)
- Protected areas (wilderness areas), nature reserves, etc.

## 2.4 Silviculture

An innovative and intensive silviculture program began in the 1960's and was formally incorporated into the 1969 agreement. In both the former agreement and the new FULA agreement, a portion of the agreed stumpage payments (government fees collected from commercial timber harvesting) are allocated to the silviculture program. The stumpage may be supplemented with additional funding for the agreement Crown lands which is designed to increase the yield and quality of wood produced within the principles of sustainable development. PHP's forest operations in Nova Scotia have implemented a modern silviculture program including full reforestation of all harvested areas and stand tending treatments of young forests.

Supplementary agreements to the original license have been cooperatively entered into by PHP and the Nova Scotia Department of Natural Resources (NSDNRR). These agreements have provided funding for increased silviculture effort on Crown lands to restore forest health and productivity following fires, insect infestations, windstorms and other natural disturbances. Both PHP and the NSDNRR have contributed funding to these programs.

## 2.5 Rights and Regulations

The Woodlands Unit at PHP is responsible for all forest planning on company managed lands. Forest planning on company managed Crown lands are subject to the terms of the Forest Utilization Licence Agreement. It allows the company to harvest wood, perform silviculture activities, and build roads for access to the licensed area. The agreement includes the preparation of annual and long-term forest management plans, work schedules and reports. NSDNRR is responsible for land-use and resource-use decisions pertaining to the DFA.

## 2.6 Legislation and Regulatory Requirements

A list of all relevant legislation and regulatory requirements that relate to the DFA is included in the Woodlands' Unit Environmental Management System (EMS). The list provides details of legal requirements associated with the forest, where this information can be obtained, and how this information is systematically updated. The EMS includes a description of the forestry activities associated with specific legal requirements.

## 2.7 Forest Workers in Defined Forest Area

A DFA-related worker is any individual employed by the company to work for wages or a salary who does not have a significant or substantial share of the ownership in the employer's organization and does not function as a manager of the organization. PHP promotes the legal constitutional rights, and health and safety of DFA-related workers. Company silviculture crews are unionized members of the Canadian Papermaker and Energy workers union. The collective agreement contains many articles relating to worker safety. Contractor employees work in a non-union environment.

PHP maintains a joint Occupational Health and Safety Committee that convenes twice per year. Each company crew has a safety representative that is a member of the joint Committee. Contractors also have their own safety committees required under the Nova Scotia Occupational Health and Safety Act. In addition, PHP maintains a Safety and Environmental Review Committee that meets regularly to discuss contractor operation issues.

# 3 LAND-BASE DESCRIPTION

PHP's Defined Forest Area (DFA) is located in the seven eastern counties of Nova Scotia. The geographic extent of the DFA is shown in Figure 1. The company manages approximately 510,342 hectares of Crown lands through a license agreement with the provincial government within the DFA. The land inventory managed by PHP is broken down into four main components (Table 1).

The PHP FULA lands total 510,342 ha in the Eastern region. Crown Wilderness Areas (72,486 ha of existing and pending protected area) are protected lands which contribute to non-timber values in the forest model. Contributing to the wood basket along with the PHP FULA lands are available unlicensed

crown in the Eastern region as approved by NSDNRR. Crown wood in central and western Nova Scotia are not included in this plan.

In addition to acquiring wood from PHP company managed lands, the company harvests wood from private woodland owners through short-term stumpage leases. Private wood is also procured from private suppliers that operate on private woodlands located in central and eastern Nova Scotia. Wood is purchased at roadside and the company provides competitive pricing. In addition, the company provides silviculture services and training in sustainable forest management practices to encourage good stewardship practices.

The public use of Crown lands for recreation, accessibility, hunting and fishing, to name a few, illustrates the wide variety of values held by the general public. Tourism plays an important role in the regional economy; as a result, unique challenges in meeting the needs of all stakeholders must be assessed and managed appropriately. The NSDNRR has implemented an integrated resource management (IRM) land use approach for the management of Crown lands.

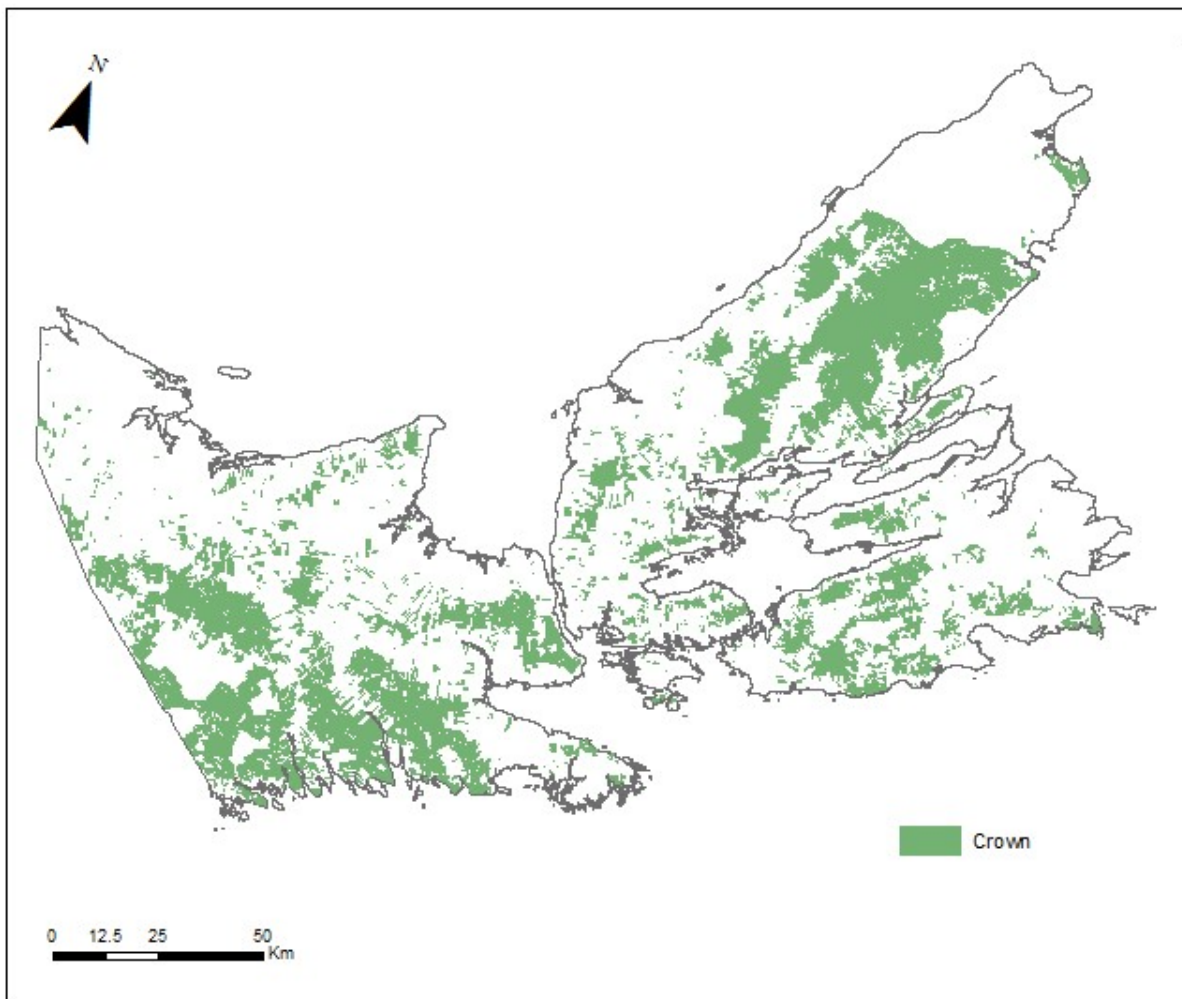

Figure 1. Map of PHP's FULA Land-base



### 3.1 Land-base Netdown Process

The land-base netdown process begins with the land base's gross area and gradually reduces it in accordance with certain classification criteria. The [Appendix B: Data Package](#) contains a detailed description of all the assumptions and data that were used in the analysis. The total forest area is identified as either the forested land-base, working land-base, or working land-base with no restrictions in order to identify the working forest land-base where management activities are scheduled. The area reduced under each netdown category, as well as the present and projected working land-base with timber harvesting, are shown in Table 2.

The land-base was assembled using the photo interpreted forest inventory flown in 2008 and 2009 as a base. Historic treatment shapefiles were incorporated from PHP and NSDNR databases to update the spatial boundaries and attributes of the forest inventory. Wildlife habitat, ecosystem data, special management layers, and hydrology and roads layers were compared, agreed upon and amalgamated where appropriate to create the most recent and accurate dataset possible (NSDNR, 2021b).

As land-base layers are overlaid, attributes are coded to allow for partitioning of results based on forest and non-forest values. The total land area includes all terrestrial area (inland waterbodies are excluded), crown wilderness area and non-forested land are removed to create the forested land-base. After removing permanent exclusions (off limits to forest management prescriptions), the remainder is the working land-base which contributes to wood supply. The working land-base is largely occupied by special management lands, which dictate treatment prescription details (NSDNR, 2021b).

Table 2. Land-base Netdown for PHP License Area

<b>Analysis Unit: Eastern Crown: PHP License Area</b>					
<b>Land-base Category</b>					<b>Area(ha)<sup>1</sup></b>
<b>1 Total Land Area</b>					<b>510,342</b>
1.a Non-Forested Land	83,004				
<b>2 Forested Land-base (FLB)</b>					<b>427,338</b>
	<b>[gTLB]</b>	<b>[gFLB]</b>	<b>[nFLB]</b>		
2.a.1 Existing Protected Area	44,046	37,655	37,655		
2.a.2 Proposed Protected Area	28,440	22,672	22,672		
2.b.1 DNR Lynx Habitat Buffers	24,296	23,840	18,904		
2.b.2 DNR Moose Habitat Buffers	12,653	12,199	10,857		
2.b.3 Coastal Plains Flora Buffers	136	132	103		
2.b.4 Boreal Felt Lichen Buffers	6,809	5,157	3,966		
2.b.5 Other Special Site Habitat	1,166	858	562		
2.c DNR Old Growth Policy	40,707	40,587	9,207		
2.d Inoperable/Subjective Removals	36,777	34,260	19,545		
2.e Other Regional Harvest Exclusions	2,235	2,179	1,396		
2.f Aboriginal Offered Lands	100	99	6		
2.g.1 Regulation Watercourse Buffers (20m)	32,936	32,031	12,039		
2.g.2 Main River Watercourse Buffers (100m) (Crown)	103	102	64		

2.g.3 Non-Watercourse Open Bog Buffers (20m) (Crown)	1,932	1,897	522		
2.h Sensitive Forest Groups (Crown)	5,428	5,378	5,378		
2.i Draft IPCA (Crown)	6,655	5,917	2,986		
	<b>2 FLB Exclusions Sub-Total</b>			<b>145,861</b>	
<b>3 Working Land-base (WLB)</b>	<b>[gTLB]</b>	<b>[gFLB]</b>	<b>[nFLB]</b>	<b>[nWLB]</b>	<b>281,477</b>
3.a.1 Non-Watercourse Treed Bog Buffers (20m) (Crown)	10,590	10,456	4,839	4,839	
3.b.1 Marten Patches	23,163	21,267	9,271	9,232	
3.b.2 Deer Wintering Areas	21,581	17,531	10,761	10,591	
3.b.3 Mainland Moose Concentration Areas	199,237	164,334	121,116	110,772	
3.b.4 Wood Turtle Habitat	4,418	3,892	2,332	295	
3.b.5 BFL Habitat buffers 200-500m	27,281	21,565	13,705	6,968	
3.b.6 BFL Bicknell's Thrush Habitat Areas	68,006	52,998	34,728	33,491	
3.c Rare Ecosections	25,156	17,812	10,962	3,430	
3.d Protected Areas 100m Buffer	12,573	10,862	8,373	2,403	
3.e Corridors	44,559	36,717	21,465	6,309	
3.f PHP Watershed (Margaree/St. Mary's)	90,599	79,844	58,802	8,073	
3.g IRM - C2 Areas	267,547	224,939	129,115	40,934	
	<b>3 WLB Restrictions Sub-Total</b>			<b>237,338</b>	
<b>4 WLB No Restrictions</b>					<b>44,139</b>
					<b>NSCLFM Land-base2021v1a</b>
<sup>1</sup> All area statistics exclude water					
<sup>2</sup> TLB, FLB and WLB were prefaced with 'g' indicating total intersect area and 'n' indicating intersect area after previous					

The above table uses the following area statistics for exclusion category description (NSDNRR, 2021b):

- **gTLB: Gross Total Land-base:** This category reports the total land-base area contained inside the whole exclusion category, excluding any overlap with other exclusion categories. The gTLB statistic does not include any inland water body area.
- **gFLB: Gross Forested Land-base:** Only the forested area that falls within the exclusion category's boundaries is reported in this area statistic. What is or is not regarded to be forested is determined using data from the forest inventory. The [fornon] and [species] attributes from the photo-interpreted forest inventory are used to form the rules for classifying forested land-bases. A stand is regarded as being a part of the forested land-base if it has a valid [species] label or, in the absence of a [species] label, a [fornon] code indicating the potential to become a forest stand in the future. The loss of land for roads and trails that were not included in the main forest inventory is one exception.
- **nFLB: Net Forested Land-base:** The forested area inside the exclusion category's boundaries that hasn't already been taken into consideration by earlier exclusion categories is reported by this area statistic. Since there is no double counting in the nFLB area, these areas can be added to get accurate totals.

- nWLB: Potential Working Land-base:** The forested area inside the exclusion category's boundaries that does not overlap with any other exclusion categories is reported by this area statistic. The nWLB offers a way to evaluate potential benefits to the working land-base that come with eliminating any particular exclusion category. Since they are category-specific, it is impossible to sum them up without first addressing any overlap between newly released categories.

Figure 2 shows the distribution of these categories within the forest management area by total land area available.

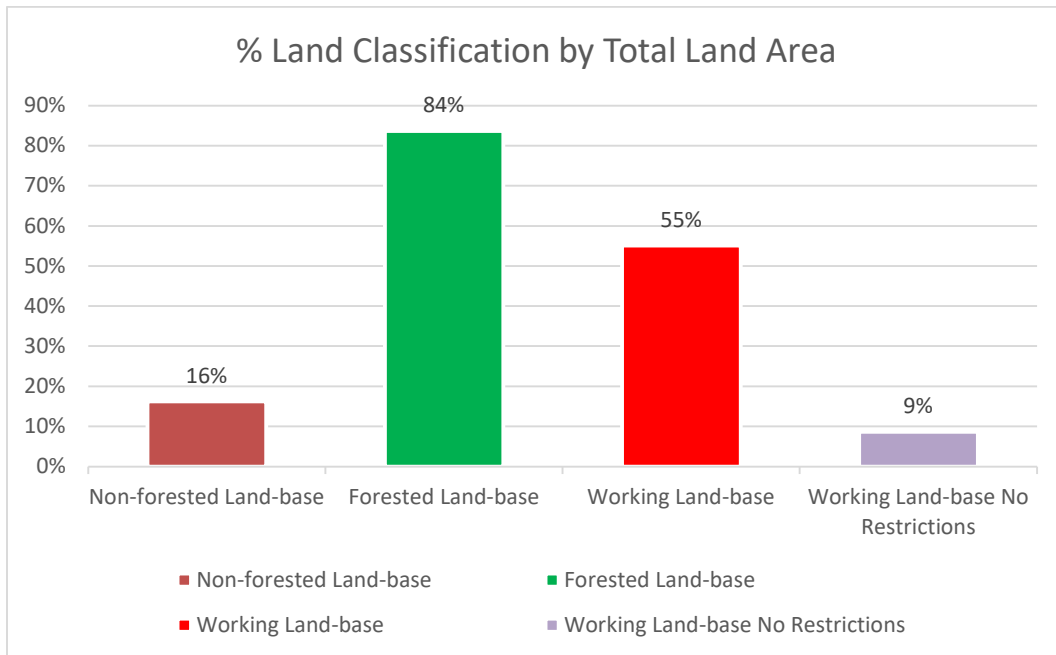

Figure 2. Percent Land Classification by Total Land Area

Even though the strategic forest model makes use of the complete forested land-base (FLB), only a fraction of this, known as the "working land-base," is available for scheduling forest management operations (WLB). The complete FLB is not included in the working land-base due to numerous operational and policy requirements (i.e., protected areas, old forest policy, wildlife habitat buffers, watercourse buffers, inoperable stands, etc.).

## 4 ECOLOGICAL LAND-BASE DESCRIPTION

The Nova Scotia Department of Natural Resources have recently refined the Ecological Land-base Classification (ELC) system. PHP has fully aligned with the new ELC and it is used as the planning framework for all habitat, economic, social, and timber supply objectives at all scales of planning. For instance, the Uplands ecoregion is broken down into seven separate ecodistricts.

### 4.1 Ecoregions

Ecoregions replace the previous PHP EPU layer. The layers are very similar; however several boundaries were not coincident. Ecoregions classify PHP's FULA lands into six regional categories. Ecoregions are primarily delineated based upon differences in climatic and geological conditions.

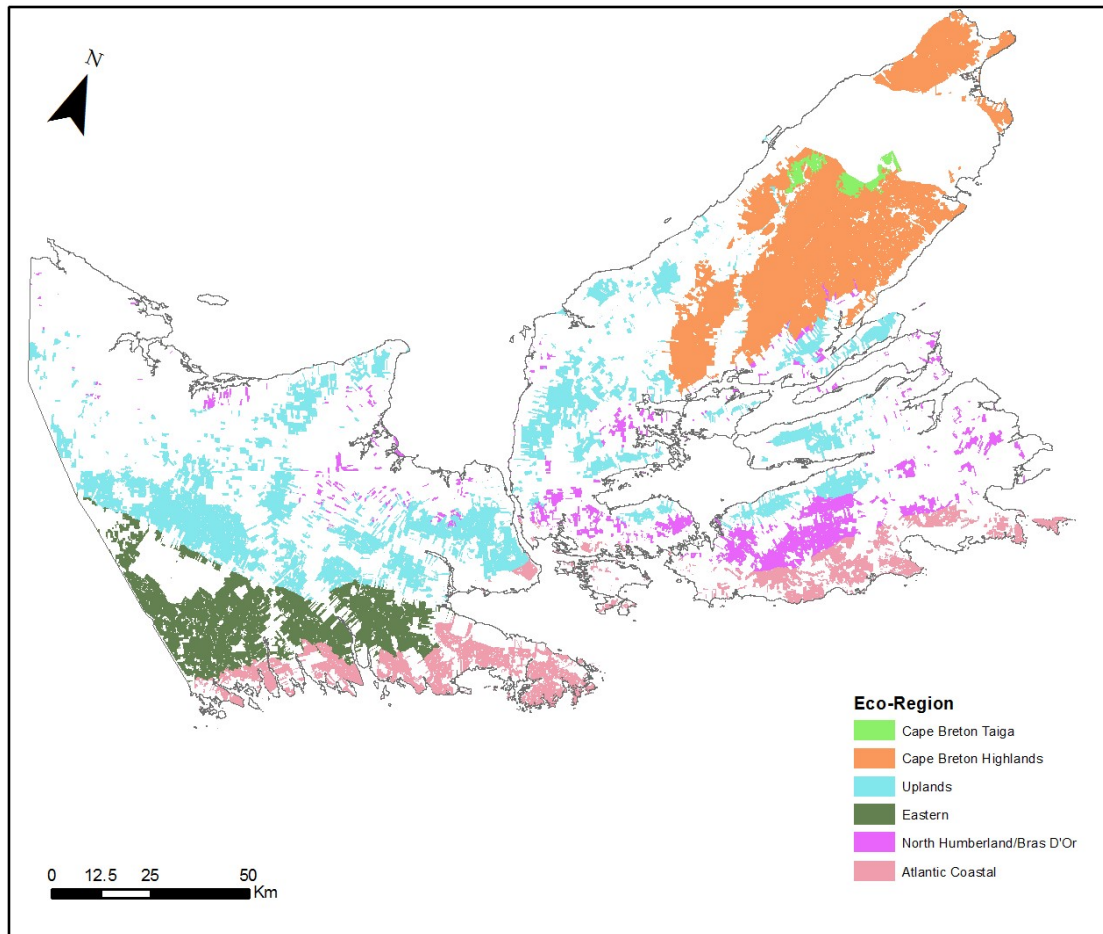

Figure 2. Map of Ecoregions of PHP's FULA Land-base

## 4.2 Ecodistricts

We can further breakdown each Ecoregion into smaller management units called ecodistricts, which has been incorporated into our planning process and will be reported on more prominently for the foreseeable future. The 18 ecodistricts have boundaries which coincide with the ecoregion boundaries therefore allowing the ability to roll up or down scales depending on the analysis.

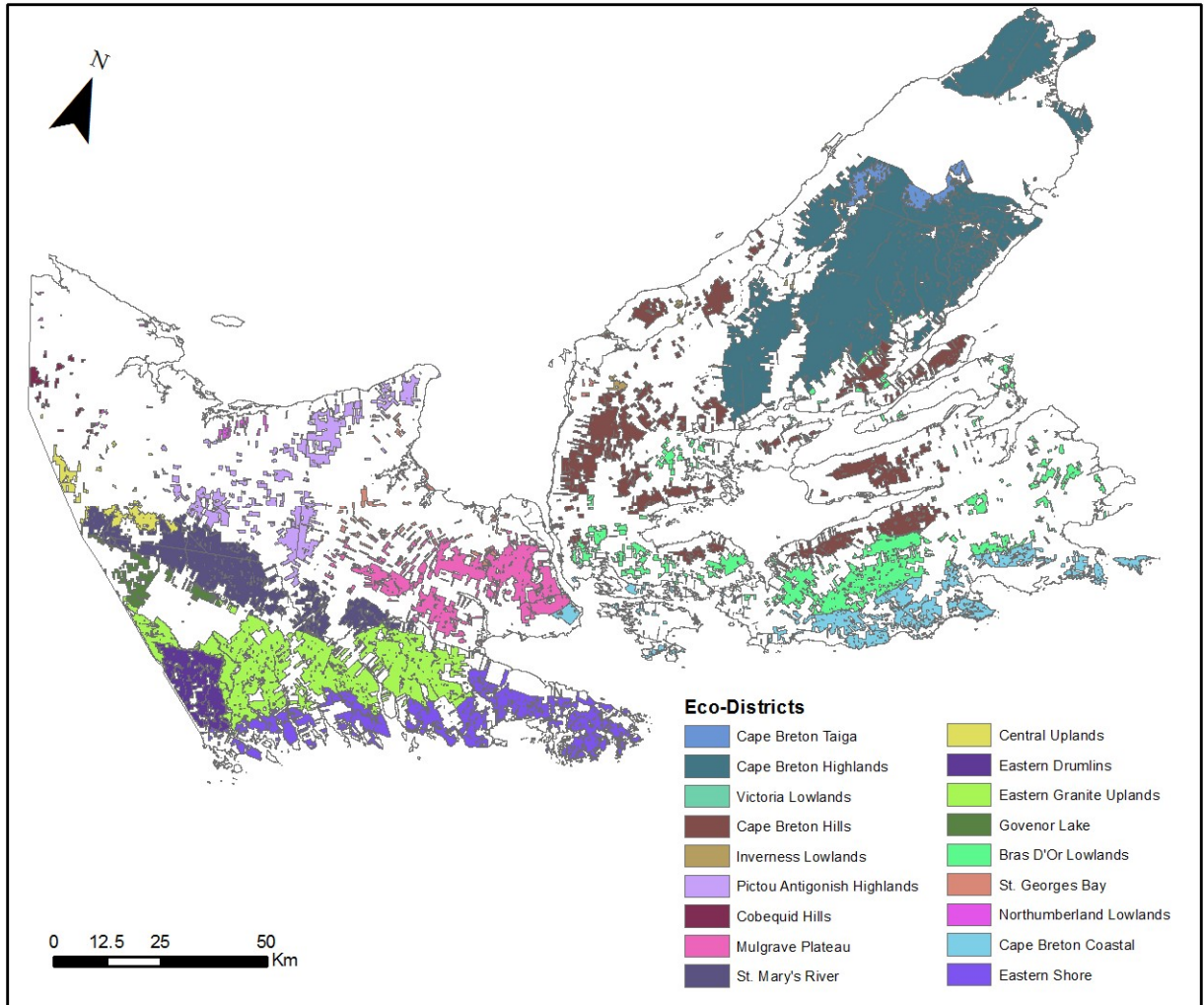

Figure 3. Map of Ecodistricts of PHP's FULA Land-base

### 4.3 Forest Elements

At a fine scale and spatially represented, forest elements represent a climax forest community that is influenced by the soil moisture and nutrient regimes as well as topography. Regional climate and natural disturbance regimes influence these ecosystems. Forest Elements promote an understanding of successional vegetation patterns and the effects of forest disturbances. The following figure displays an example of forest elements contained in ecodistrict 330 – Pictou Antigonish Highlands which falls under the Upland ecoregion.

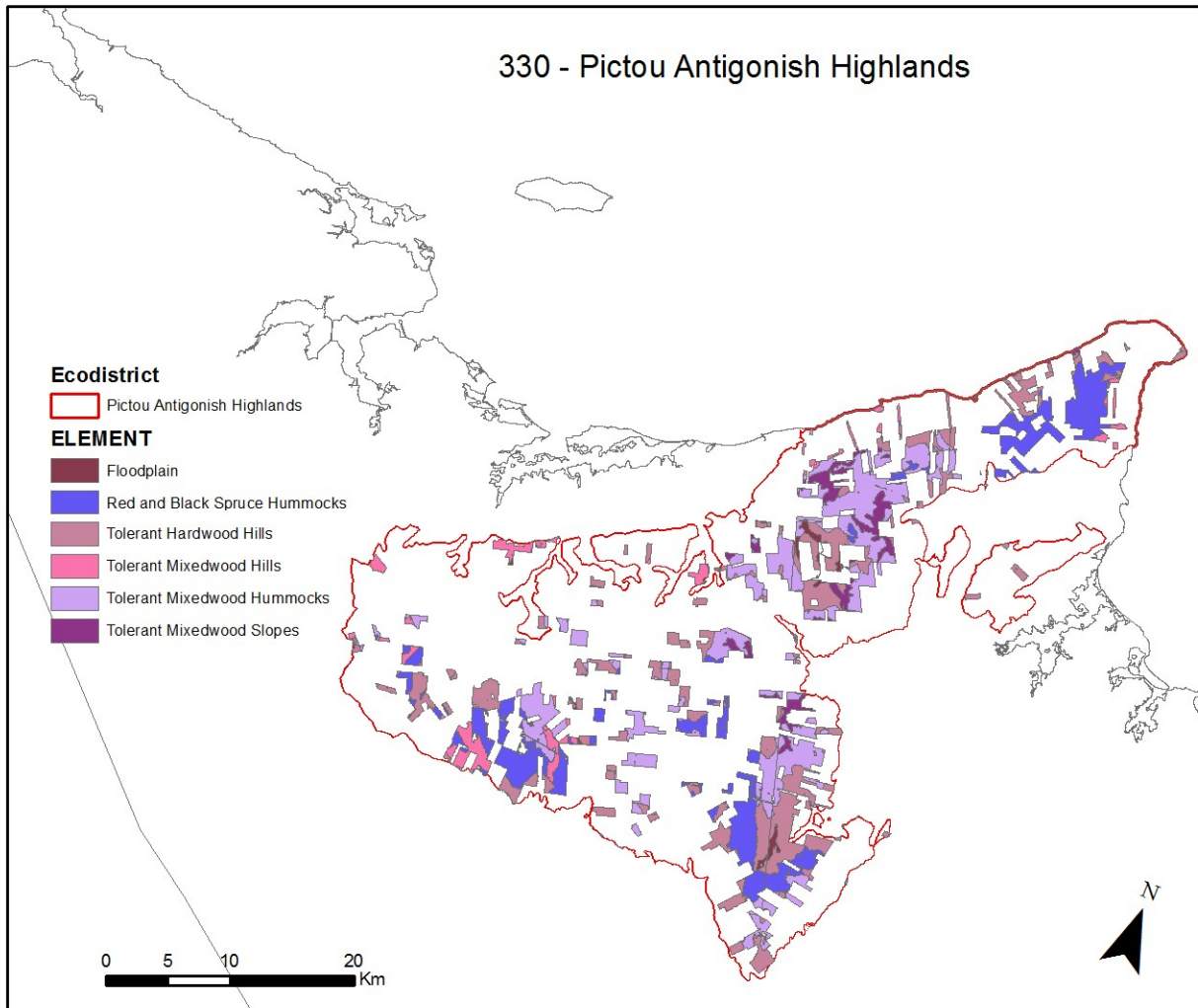

Figure 4. Map of Forest Elements of Ecodistrict 330



## 5 FSC DEFINED PLANTATIONS

Currently, Port Hawkesbury Paper does not have FSC plantations as defined by the FSC Canada National Standard for Forest Management. As PHP moves towards the triad management system, and high production areas are identified with clear management options, PHP will re-assess whether the high production areas are considered an FSC plantation which is defined as:

A *forest\** area established by planting or sowing with using either *alien\** or *native species\**, often with one or few species, regular spacing and even ages, and which lacks most of the principal characteristics and key elements of *natural forests\**. The description of plantations may be further defined in FSC Forest Stewardship Standards, with appropriate descriptions or examples, such as:

- Areas which would initially have complied with this definition of ‘plantation’ but which, after the passage of years, contain many or most of the principal characteristics and key elements of *native ecosystems\**, may be classified as *natural forests\**.
- Plantations\* managed to *restore\** and enhance biological and *habitat\** diversity, structural complexity and *ecosystem\** functionality may, after the passage of years, be classified as *natural forests\**.
- Boreal and north temperate *forests\** which are naturally composed of only one or few tree species, in which a combination of natural and artificial regeneration is used to regenerate *forest\** of the same *native species\**, with most of the principal characteristics and key elements of *native ecosystems\*s* of that site, may be considered as *natural forest\**, and this regeneration is not by itself considered as conversion to plantations. (FSC-STD-CAN-01-2018-EN)

PHP is committed to restoring the Acadian Forest where appropriate given the historical abundance of farms in Nova Scotia and their subsequent abandonment. The managed land-base PHP has inherited contains a small fraction of converted forest groups given the intensive Silviculture of the late 1980’s. PHP has identified 5,583 ha of land in its license that was converted from Tolerant Hardwood to mostly White Spruce plantations between 1980 and 1987. During that time, herbicides were used to maintain softwood composition.

Forest management practices have greatly evolved since the late 1980’s; herbicides have not been used by the company since 1997, as well as work instructions pertaining to pre-commercial thinning species retention. Late successional species are given higher priority in all stands with the goal of enhancing natural biodiversity throughout the managed land-base. Harvesting prescriptions are based upon the Forest Ecosystem Classification guide in which, soils play a detrimental role in determining the successional pathway to follow.

A significant portion of the identified converted forest lies within the Cape Breton Keppoch, an infrequently disturbed Ecodistrict. Infrequent stand initiating disturbances generally lead to the establishment of mid to late-successional vegetation types. Acceptable treatments for these stands with the goal of restoration include shelterwoods, patch cuts, partial cuts, and Commercial Thinning. These treatments will encourage Yellow Birch regeneration through openings and scarification and will help convert the stands back to more uneven aged with enhanced natural biodiversity.



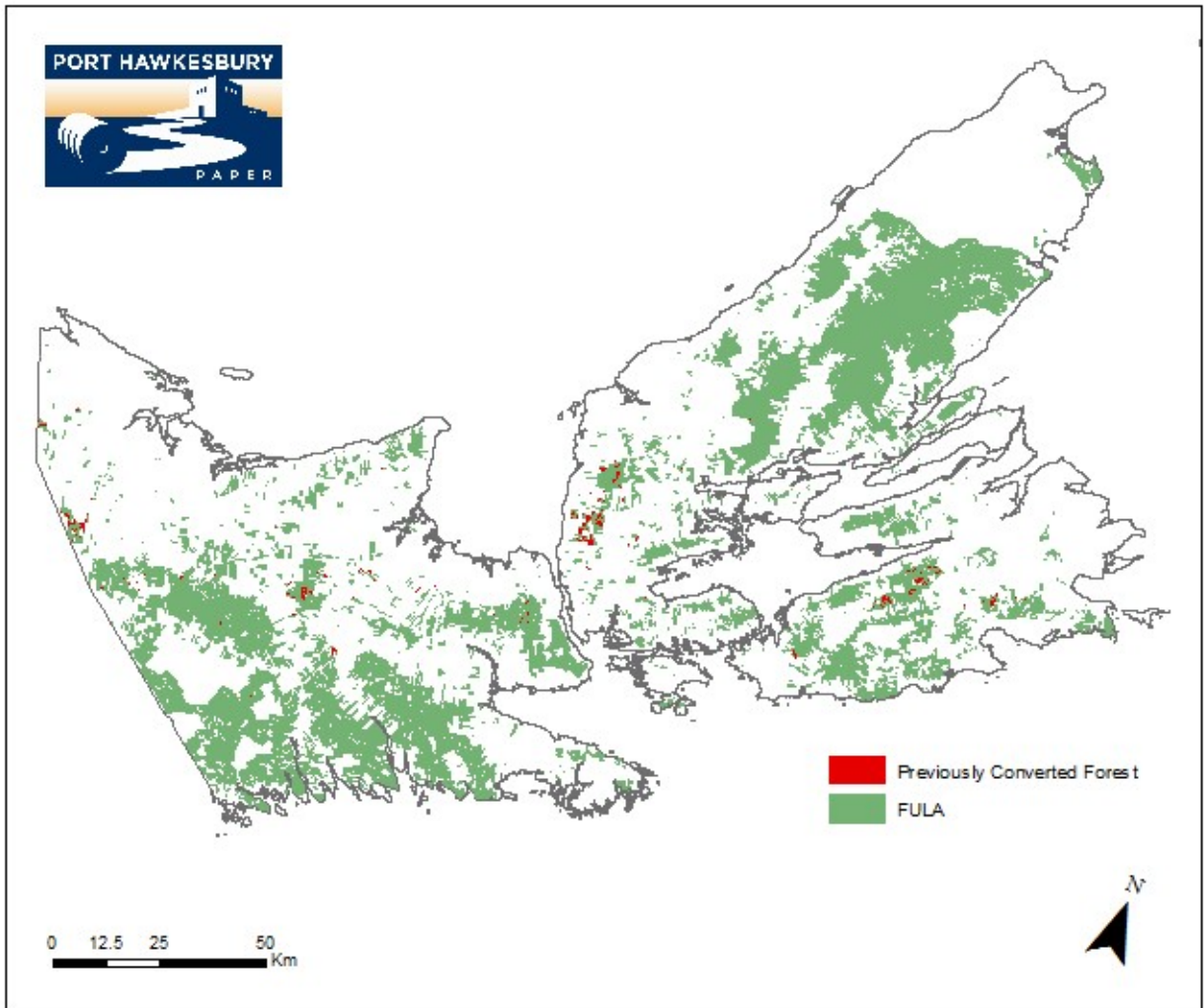

Figure 5. Map of Area of Previously Converted Forest

## 6 FOREST COMMUNITIES

A crucial stratification for strategic planning is the forest community. It offers a way to organise around 90,000 different species stand calls according to dominating tree species affiliations. Over 40 distinct tree species are used in photo interpretation, and each species is given a percentage of the crown closure in 10% classes, with a total of 100% for all the species. Up to four different species may be allocated. For instance, a stand with the label "RS10" would be entirely made of red spruce, whereas a stand with the label "BF05RM05" would be split equally between balsam fir and red maple by crown closure. The NSDNRR created the taxonomy of forest communities in 2005 to be used in strategic forest planning.

Due to recent harvests or the height of stands being too short to interpret species, significant areas of the forest inventory on the forested land-base have no species call. This is referred to as "unclassified regeneration" in the modelling process. If treatment records are not accessible, historical inventory (prior photo interpretation) data was employed as a source of species information in this case. If neither is available, a default forest community of "MIHwSH" is assigned. The forest community theme has 12 unique natural forest community codes and 5 plantation codes for a total of 17 possible codes as shown in the table below.

Table 3. Forest Community Types

Name	State	Description
HIHw	Natural	Hardwood - Intolerant Hardwood Leading
HITHw	Natural	Hardwood - Mixed Tolerant/Intolerant
HTHw	Natural	Hardwood - Tolerant Hardwood Leading
MIHwSH	Natural	Mixedwood - Intolerant Hardwood - Softwood Leading
MTHw	Natural	Mixedwood - Tolerant Hardwood Leading
SrSbSDo	Natural	Softwood - Red/Black Spruce Dominant
SwSDom	Natural	Softwood - White Spruce Dominant
SbFDom	Natural	Softwood - Balsam Fir Dominant
SSpbFDo	Natural	Softwood - Spruce/Fir Dominant
SPiDom	Natural	Softwood - Pine Dominant
SMHePiS	Natural	Softwood - Mixed Hemlock/Pine/Spruce
SrSPL	Planted	Softwood - Planted Red Spruce
SbSPL	Planted	Softwood - Planted Black Spruce
SwSPL	Planted	Softwood - Planted White Spruce
SwPPL	Planted	Softwood - Planted White Pine
SExPL	Planted	Softwood - Planted Exotic Species

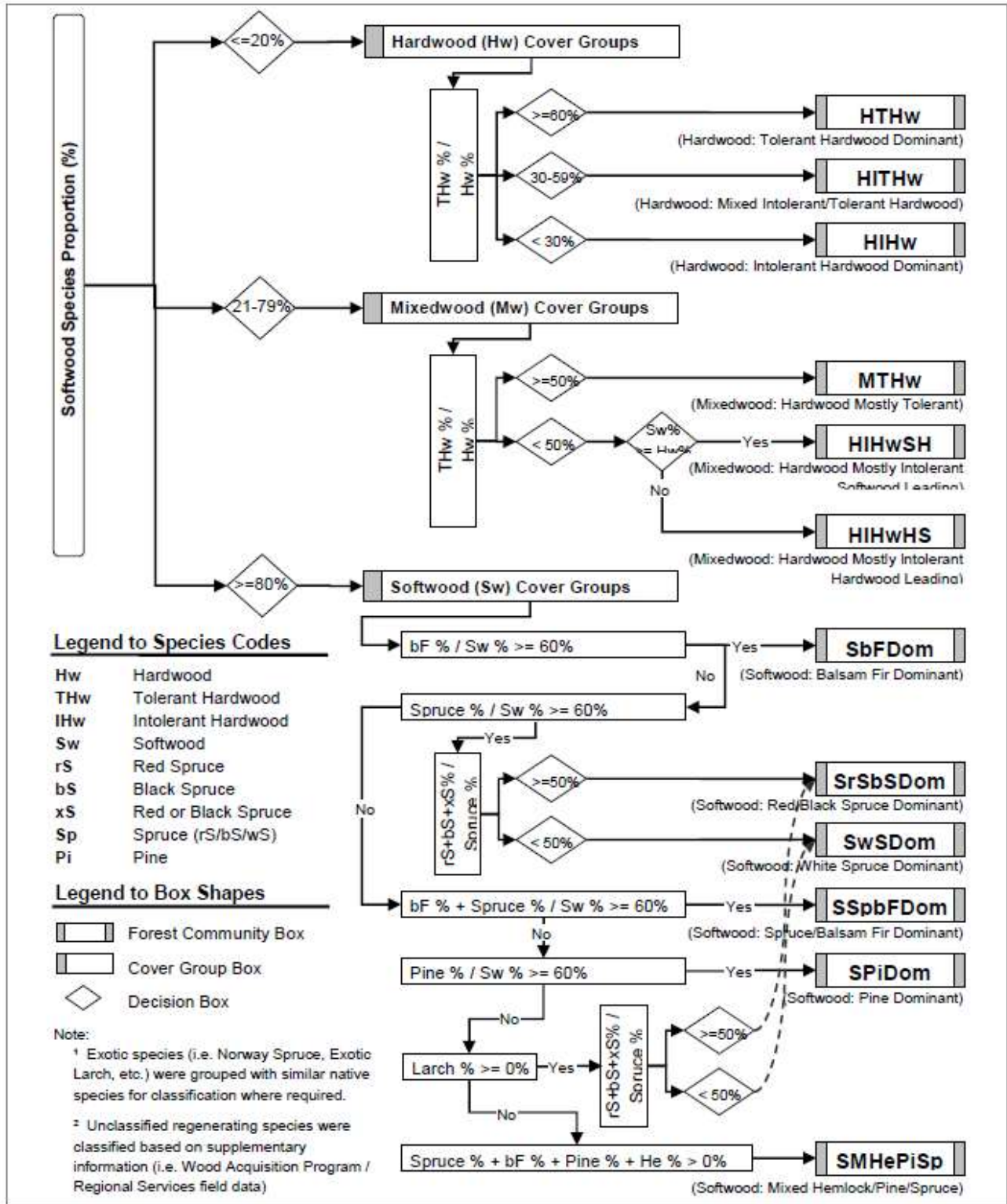

Figure 7 – Forest Community Assignment Rules

## 7 PUBLIC OUTREACH

### 7.1 Forest Advisory Committee

The Forest Advisory Committee (FAC) was established in 2000 for the Woodlands Unit at Port Hawkesbury Paper LP (PHP). The committee's main function is to provide an ongoing and interactive opportunity for meaningful public participation in forest management decisions and two-way flow of information from the public to the company and back again.

The FAC includes representatives from a variety of public interest groups including youth, woodlot owner, contractor, small industry, tourism, recreation, Aboriginal, community development, small business, academia, government, environmental, community, and forest education. The views of these public interest groups and individuals are brought to PHP's Woodlands Unit through the FAC; they assist the company to identify, understand, and prioritize forest related issues. In addition to meeting at least three times per year, FAC members participate in an annual field tour of PHP's forestry and forestry related operations.

### 7.2 General Stakeholder Engagement

Apart from our Forest Advisory Committee, PHP LP practices meaningful stakeholder engagement in a variety of ways. In addition to our formal inquires and third-party requests processes, individuals and groups can find information and express their concerns through our *Leader in Sustainability & Outreach* and by contacting our regional woodlands staff.

We annually meet with municipal councils in our forest management region and host public open house events. Our publicly available *Green Balance Report* offers a comprehensive look at our environmental and safety performance for each year of operation.

### 7.3 High Conservation Value Forests

High Conservation Value Forest (HCVF) areas are also monitored annually to evaluate whether desired management activities are being met to ensure maintenance or enhancement of a high conservation value (HCV). Additionally, HCV's are monitored annually for new research and/or data compiled by relevant organizations to track whether HCV characteristics and management activities are current and still relevant.

## 7.4 Aboriginal and Treaty Rights

PHP respects Aboriginal and Treaty Rights and will continue to comply with all legal requirements and land use decisions identified by the federal and provincial governments. PHP has no direct treaty obligations to Aboriginal peoples but will continue to provide for economic opportunities with First Nations communities in areas where its operations impact Aboriginal and Treaty Rights. In recent years, PHP worked with the Unama'ki Institute of Natural Resources to provide employment opportunities for Aboriginal peoples on Cape Breton Island. The company has signed a Memorandum of Understanding with the Assembly of First Nations and Kwilmu'kw Maw-klusuaqn (KMK - also known as Mi'kmaq Rights Initiative) towards the development of an Impact and Benefit Agreement, and an Environmental Agreement. These agreements will provide a framework for working together on matters such as employment opportunities, education and training, research, and environmental compliance and monitoring.

In 2020, PHP began a Free Prior Informed Consent (FPIC) process with all Mi'kmaq communities in Nova Scotia. This process aims to engage Mi'kmaq communities that may have legal and/or customary rights potentially affected by PHP's management activities through a Free Prior Informed Consent process. This will allow for participation in forest management planning to the extent necessary to protect their rights, resource lands and territories. The scope of engagement includes planned forest management activities on the licensed Crown lands in eastern Nova Scotia and to meet the requirements of the FSC National Standard Principle 3 requirements.

A Free Prior Informed Consent process is best defined as:

<b>FREE</b>	Consent is given without coercion, intimidation, or manipulation.
<b>PRIOR</b>	Consent is sought before every significant stage of project development.
<b>INFORMED</b>	All parties share information, have access to information in a form that is understandable, and have enough information and capacity to make informed decisions.
<b>CONSENT</b>	The option of supporting or rejecting development that has significant impacts on Aboriginal lands or culture.

PHP's main goals related to FPIC are:

- meaningful input on our forest management activities
- ensure we do not negatively affect traditional rights of Mi'kmaq communities
- two-way communication and sharing of knowledge regarding significant Mi'kmaq areas within the PHP Crown license

- achieve a FPIC agreement for both parties to describe the relationship and requirements for how information is shared collaboratively
- receive Mi'kmaq recommendations and/or objections regarding our planned forest management activities

PHP has also collaborated with Mi'kmaq organizations on the Mi'kmaq Forestry Initiative, Indigenous Protected & Conservation Area, and Cultural Indigenous Landscapes. Other areas of collaboration are also being framed through an Umbrella Framework Agreement that outlines initiatives of interest between PHP and the Mi'kmaq.

PHP is also committed to respecting other users of the crown license lands under section 8 of the 2022 FULA agreement:

### 8.1 *Mi'kmaq Use*

- (a) *Section 35 of the Constitution Act, 1982, protects the existing Aboriginal and treaty rights of the Mi'kmaq, and PHP agrees that it will*
- i. *provide the Mi'kmaq with continued access to the Agreement Lands for traditional activities (fishing, hunting, harvesting of wood for domestic purposes); and*
  - ii. *protect known archaeological sites and implement measures to minimize risk in areas of high archaeological potential and Mi'kmaq culturally important sites within the Agreement Lands and provide the Mi'kmaq with continued access to those sites.*

8.2 *PHP shall maintain and update a written process that outlines how it will engage the Mi'kmaq about proposed operations on Agreement Lands and how the Mi'kmaq may inform PHP and the Province in a timely manner of any potential adverse effects as a result of those operations. PHP shall develop the protocol in collaboration with the Assembly of Nova Scotia Mi'kmaq Chiefs and with impacted individual Mi'kmaq communities not represented by the Assembly. The protocol shall address, but not be limited to, the following:*

- (a) *making available proposed and revised Long-term Forest Plans with reasonable time for Mi'kmaq input and accommodation;*
- (b) *an annual review of the proposed Annual Operations Plan with reasonable time for Mi'kmaq response;*
- (c) *facilitating Mi'kmaq communities and their members for identifying and recording potential adverse effects of PHP's forestry operations;*
- (d) *developing and recording avoidance or mitigation responses; and*
- (e) *the protocol shall not act to replace or amend the Mi'kmaq-Nova Scotia-Canada Consultation Terms of Reference, or successor agreements.*
- (f) *The Province, Canada and the Mi'kmaq entered into an Umbrella Agreement on June 7, 2002, in which all three Parties recognized there are outstanding constitutional rights issues amongst them, including Aboriginal rights and treaty rights;*



- (g) Pursuant to the Umbrella Agreement, on February 23, 2007 the Parties signed the Mi'kmaq-Nova Scotia-Canada Framework Agreement that established the negotiation process for the resolution of issues respecting Mi'kmaq rights and title;
  - (h) PHP acknowledges that this Agreement is subject to any negotiated agreements between the Province, Canada and the Mi'kmaq, or the Province and the Mi'kmaq with respect to such rights on the Agreement Lands;
  - (i) The Province may require that PHP modify its forestry plans for the Agreement Lands to accommodate Mi'kmaq rights;
- 8.3 Prior to approving the Long-term Forest Plans, if the Province considers the PHP to not have adequately engaged with the Mi'kmaq in the development of the protocol document, the review of the plans, or made reasonable efforts to negotiate, enter into, and implement a Memorandum of Understanding, the Province may itself engage further, or require PHP to do so.
- 8.4 In addition to the provisions set out in this Section, the PHP is committed to meet or exceed the practices, policies and standards for engagement with indigenous peoples set out in Forest Stewardship Council Canada's National Forest Stewardship Standard – Principle 3.
- 8.5 To the extent that PHP is required to modify its Forest Management Plans for the Agreement Lands to accommodate Mi'kmaq rights, and such accommodation has a material impact on the commercial terms of this Agreement, the process in Section 4.6 shall apply to determine if the PHP is entitled to any compensation at fair market value.
- 8.6 PHP shall make reasonable efforts to negotiate, enter into, and implement a Memorandum of Understanding or Memoranda of Understanding with the Mi'kmaq of Nova Scotia, which includes the Assembly of Nova Scotia Mi'kmaq Chiefs and/or such individual Mi'kmaq communities as may be participants in a Memorandum of Understanding, to benefit from economic and partnership opportunities derived from the Agreement Lands.

Port Hawkesbury Paper LP has publicly committed to create employment opportunities for Mi'kmaq people equal to a minimum of 8% of the full time PHP positions in the aggregate direct labour force. The company believes that having Mi'kmaq people gainfully employed will strengthen our employee team and is good for the social fabric of the communities we live and work in. Port Hawkesbury Paper LP will also investigate business partnerships with Mi'kmaq communities and business developers including Mi'kmaq controlled businesses.



## 8 Monitoring

### 8.1 Environmental & Safety Management

PHP has developed a series of policies, procedures, forms, and work instructions for its Woodlands Unit staff, contractors, and forest workers. Work instructions provide guidelines and outlines procedures for conducting various forest management activities. Company staff and contractors receive training on these procedures and work instructions and/or the company's Safety & Environmental Field Handbook must be on-site at all workplaces and available to employees for review. New employees are trained in procedures as it pertains to their jobs and on-going training will be provided as required. Emergency response plans have been developed and are distributed to workers on the DFA including haul truck drivers.

### 8.2 Monitoring Program

Continual improvement and adaptive management are key elements of practicing sustainable forest management (SFM). Progress must be measured, reported, and analyzed to make certain the SFM system is succeeding. New knowledge and experience gained must be incorporated into the system to build on existing management plans and actions.

PHP's monitoring program for SFM indicators consists of internal assessments and audit programs. Each indicator has an associated monitoring and review schedule to ensure forest management decisions and actions meet desired goals and targets. PHP will evaluate those indicators that fail to meet set targets and adjust management actions accordingly to achieve the desired outcome(s). Indicators closely tied to complex computer models will be monitored through a Geographic Information System and wood supply models. Other indicators developed through less complex methods (i.e. developed with FAC or according to Best Management Practices) will be monitored through a GIS, where appropriate, or audit programs.

Each year the company produces a publicly available Annual Monitoring report which is a summary of the previous year's performance on safety, environmental and sustainable forest management progress. PHP undertakes its own internal audits of Crown and private supplier contractors and is audited annually by a third-party auditing firm to verify that PHP is meeting requirements of its FSC and SFI certification systems.

### 8.3 Internal Audits

*Company Contractor Performance & EMS Legal Compliance:* Conducted by PHP staff to ensure contractor operations comply with applicable laws and regulations, as well as PHP's policies and procedures.

*Private Supplier Compliance:* Conducted by PHP staff to monitor compliance with applicable laws and regulations, and Best Management Practices for forestry operations.

*Trucking Audit:* Conducted by PHP staff to monitor personal protection requirements, safety equipment, and truck safety requirements.

*Road Audit:* Conducted by PHP staff to monitor road construction and watercourse protection guidelines.

### 8.4 External Audits

PHP has been certified to different third-party systems over the years. Currently, the company is certified to the FSC and SFI standards for forest management. A third-party auditing company visits PHP Woodlands once a year to conduct an audit of PHP's woodlands operations and internal procedures. These audits are completed to verify that PHP is meeting all standard requirements and identify any areas of needed continual improvement. Audit results are based on a sampling of procedures, records, observations, interviews with staff and contractors, stakeholders, and rights holders. Audit reports are publicly available on the FSC and SFI websites.

### 8.5 Linkages between Long-term Plan and Annual Operating Plans

A number of tools are used to ensure that operational plans are developed and implemented in a way that meets the strategic objectives developed through the SFM planning process. This step is critical in ensuring that the SFM plan is implemented properly.

#### SFM Treatment Objectives and Targets

Area teams are given treatment area objectives annually that are in line with annual budgets and SFM objectives. Teams are responsible for developing a schedule of activities to meet these objectives.

### Work Instructions

Our work instructions are used to ensure that work procedures are carried out consistently, follow-up procedures are carried out, and any deficiencies are addressed. An annual review of the system also ensures that practices are kept in line with current best management practices.

### Appropriate Silviculture Systems

“Appropriate silviculture systems” are those silviculture treatments that have been appropriately matched with the biophysical, ecological, and climatic conditions unique to a given site or ecodistrict. Appropriate silviculture systems outline harvesting treatments determined to be most appropriate for each tree species and corresponding natural disturbance regime.

### The Forest Manager

The Forest Manager (TFM) is an enterprise GIS and reporting system used by all planning personnel at PHP. The system contains live information on areas planned, on-going and completed, and is directly linked to SFM outputs. Planning staff use this tool to plan and report on SFM treatment-based activities daily.

Specific SFM values, such as old forest, connectivity zones, identified sites of significant cultural, spiritual, or aesthetic value and wildlife habitat are identified on all maps and displays within TFM to ensure that these values are addressed in any plans developed. Specific information on the values displayed and how they should be addressed is contained in the EMS work instruction.

## 9 FOREST CERTIFICATION

Certification is a voluntary, non-governmental process used to verify independently, good forest management according to a defined standard. In addition to helping improve forest management practices, certification allows forest products to be sold to consumers with an approved label. To achieve certification, a company is audited by an accredited third-party to verify whether standard requirements are being met and/or are on their way to being met through management actions and continual improvement. Once certified, the company is audited annually with a new certificate issued for every 5-year period.

In North America, the two most widely used and respected sets of forest certification standards are created and governed by the Forest Stewardship Council (FSC) and the Sustainable Forestry Initiative (SFI). Both are autonomous, not-for-profit, multi-stakeholder organizations established to promote responsible forest management. While FSC and SFI are distinct in some respects, the core values and principles they each use in creating their standards are relatively similar.

Some common elements of each standard include:

- Indigenous rights and engagement
- Conservation of biological diversity
- Ecosystem based management
- Maintenance of wildlife habitat and species diversity
- Protection and/or maintenance of special sites (e.g., high conservation values, forests of exceptional conservation value)
- Maintenance of soil and water resources, including riparian areas next to streams and lakes
- Forest management planning
- Ensuring harvest levels are sustainable, and harvested areas are reforested
- Protection of forestlands from deforestation and conversion to other uses
- No wood from illegal or unauthorized sources
- Public and stakeholder engagement

PHP's woodland operations are presently certified to both the FSC and SFI standards. Having dual-certifications ensures that we are comprehensive in our approach to responsible forest management; assists us to remain compliant with the Forest Utilization Licence Agreement; and provides us a competitive market advantage.

## 10 WILDLIFE POLICY

There are many considerations, constraints, and goals placed in the forest model to ensure compliance with the Nova Scotia Code of Forest Practice, The FSC National Standard, and The SFI 2015-19 Standard. Values pertaining to wildlife and policy are best managed at multiple scales, with varying timelines, allowing the levels of management to mesh, and be incorporated into the model as appropriate.

### 10.1 American Marten

The American Marten (*Martes americana*) is provincially listed as an endangered species under the Nova Scotia Endangered Species Act. There are 55 patches spread throughout the Cape Breton Highlands totalling 21,804ha. These large, circular patches (refer to Figure 8) are composed heavily of spruce and fir and have had significant silviculture investment. Given the established habitat criteria of Highlands Marten (18m<sup>2</sup> basal area, 6m height, 60% crown closure), and the very low incidence of blowdown in the Highlands, commercial thinning treatments have been successful. In the forest model, Marten patches are restricted to only allow commercial thinning (CT) harvests throughout the entire 100-year plan.



Figure 6 - Commercial Thinning Operation in a Marten Patch

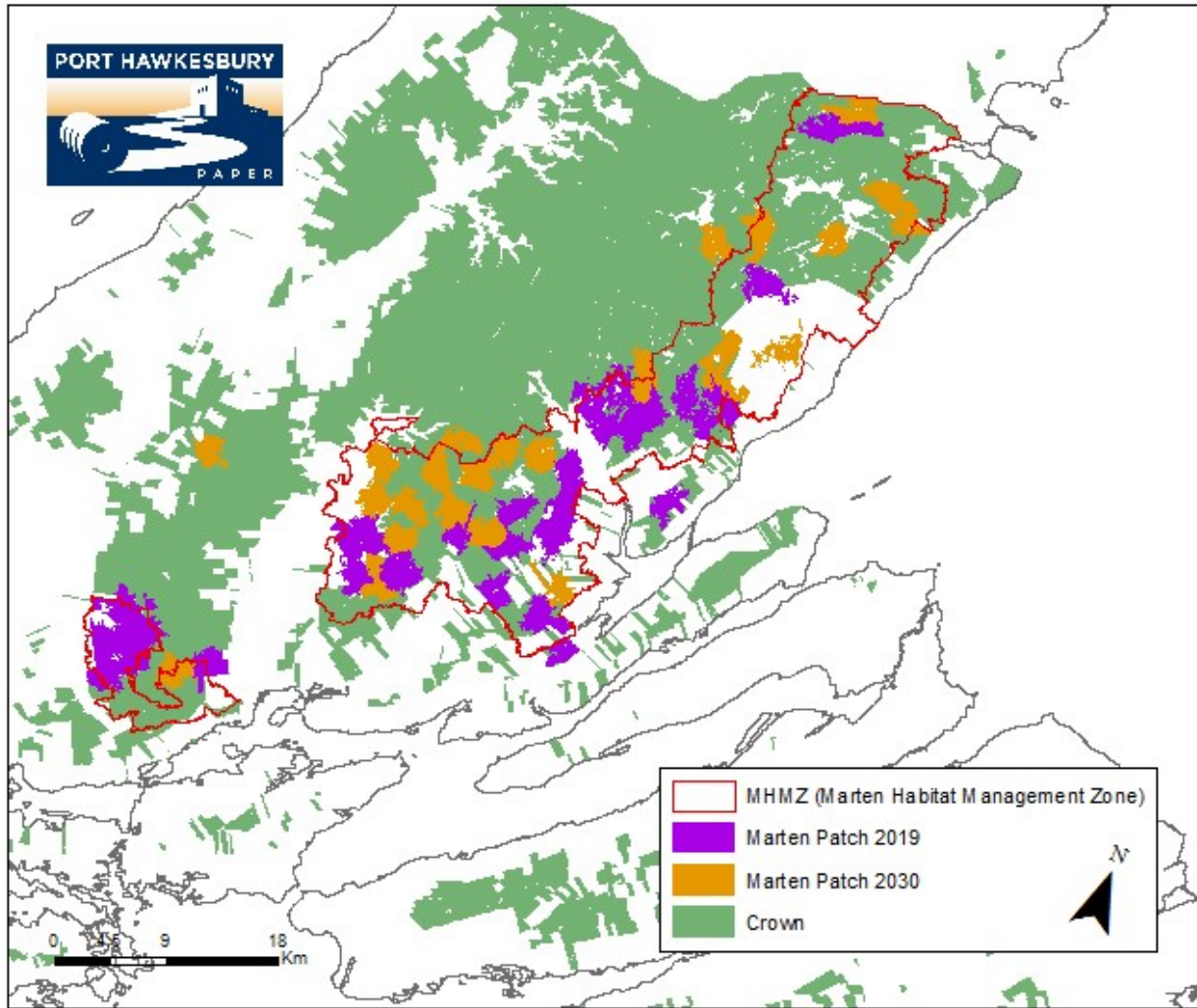

Figure 7 - Map of Marten Habitat Management Zone in the Cape Breton Highlands



## 10.2 Mainland Moose

Moose inhabiting mainland Nova Scotia are classified as endangered and special management practices are to be carried out in geographically identified concentration zones. Figure 11 displays the concentration area in eastern mainland Nova Scotia which covers roughly 80% of PHP's mainland FULA land-base. For specific information on habitat criteria and patch retention information please refer to the Sustainable Management Practice (SMP) for mainland moose in Nova Scotia. For the purposes of forest modelling predictions, harvests occurring within the concentration area have their extraction volumes reduced by 16% to reflect the wood supply impact of the Mainland Moose SMP. The 20-year landscape plan will help to facilitate patch identification at a landscape scale going forward.

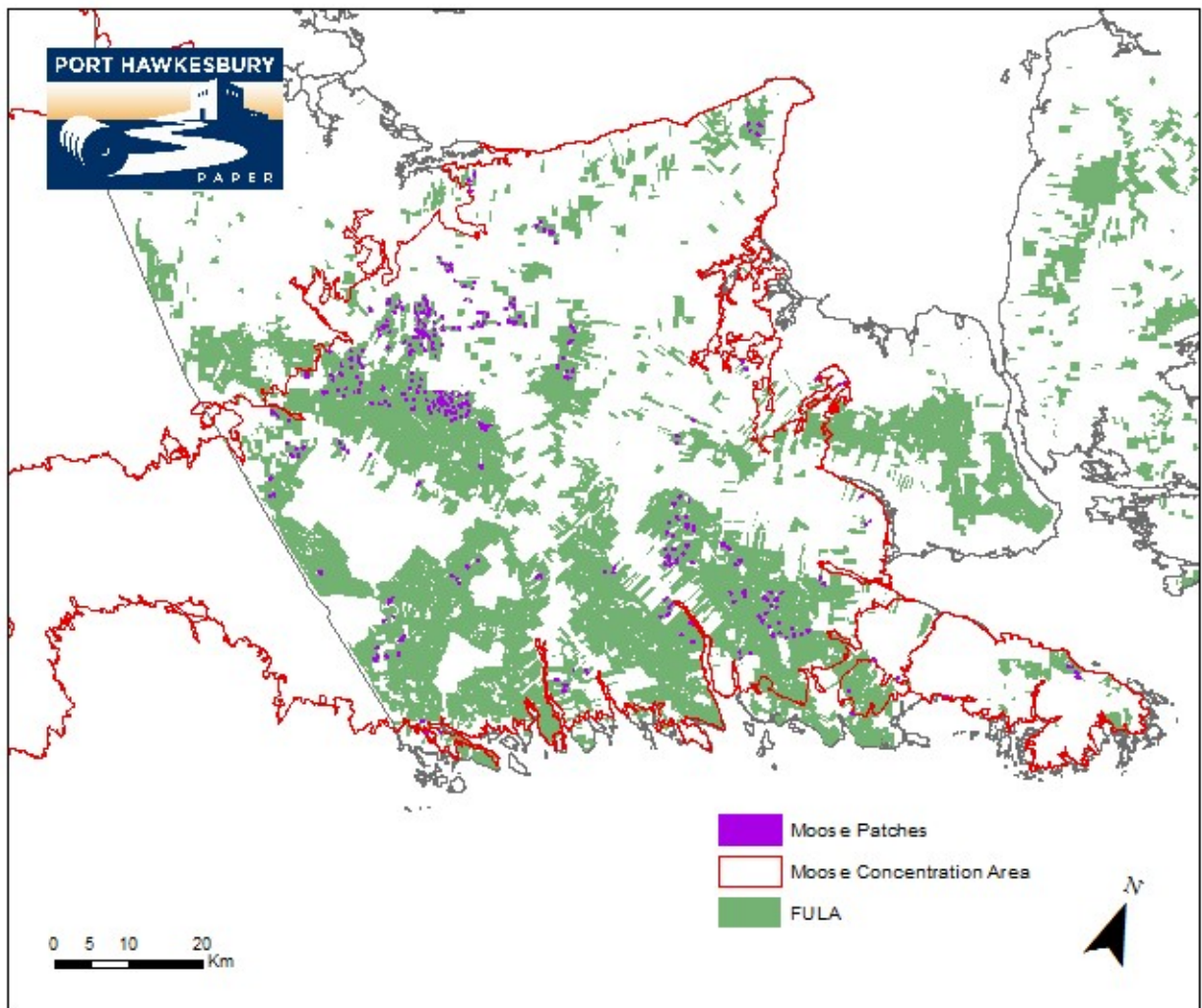

Figure 8 - Map of Mainland Moose Concentration Area and Shelter Patches



### 10.3 Deer Wintering Areas

White-tailed deer (*Odocoileus virginianus*) are a widely distributed species in North America. According to the Special Management Practices for White-tailed Deer Wintering Areas for Nova Scotia, in areas which experience harsh winters, 50% of existing conifer cover within the yard should be maintained in uncut shelter patches. These areas are identified spatially and were constrained in the model to ensure 50% or more of these patches are maintained with mature conifer cover.

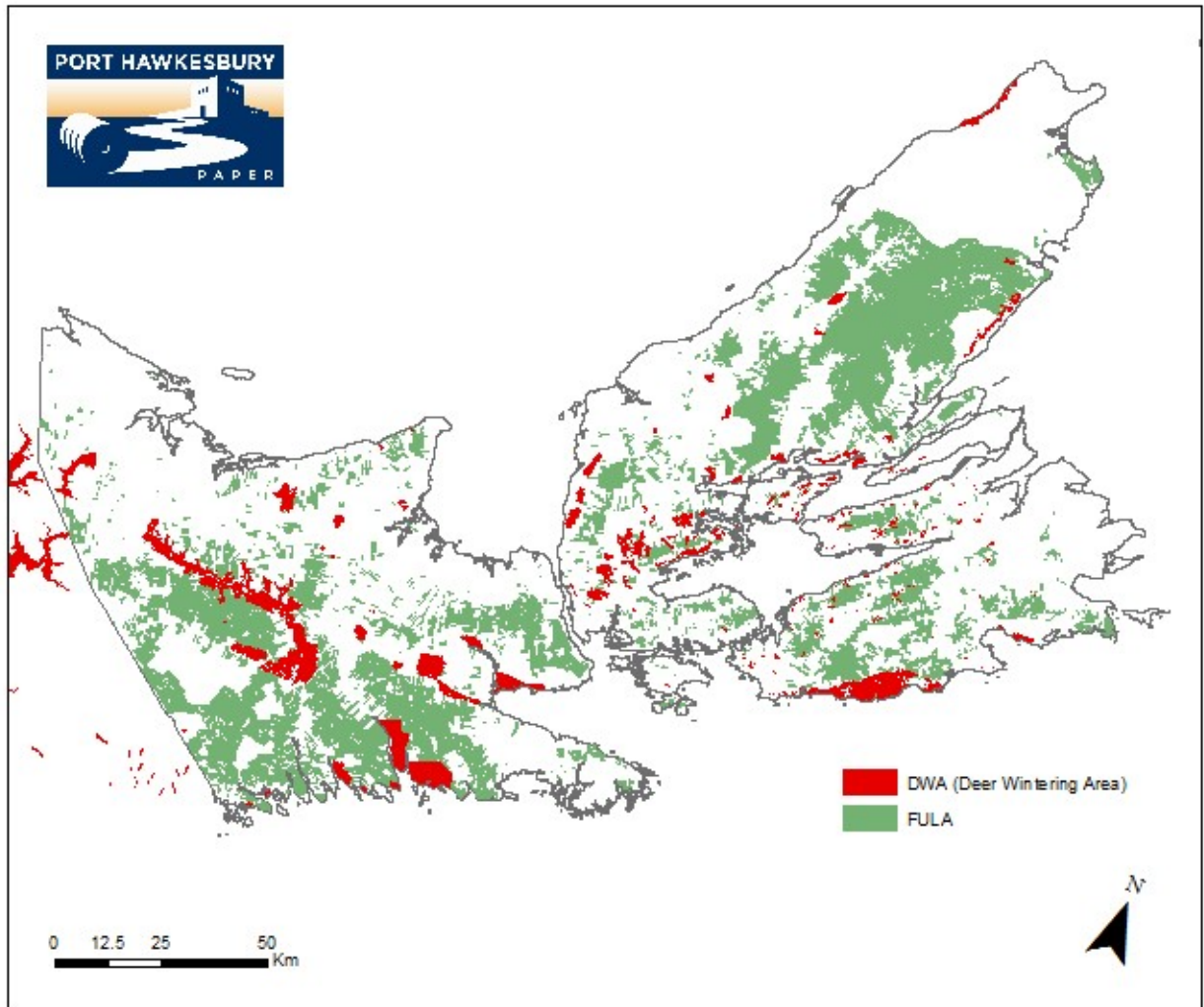

Figure 9 - Map of Deer Wintering Areas in Eastern Nova Scotia

## 10.4 Boreal Felt Lichen

Known to be found in cool, moist balsam fir stands within 25 kilometers of the southern Nova Scotia shoreline is the Boreal Felt Lichen (*Erioderma pedicellatum*). This cyanolichen is currently endangered both federally and provincially. PHP ensures all planned harvest areas within the habitat zone are assessed by a professional prior to harvest. When Boreal Felt Lichen is found, a 200 metre no-harvest zone is protected around the host tree with an additional 300 meter zone identified for special management practices.

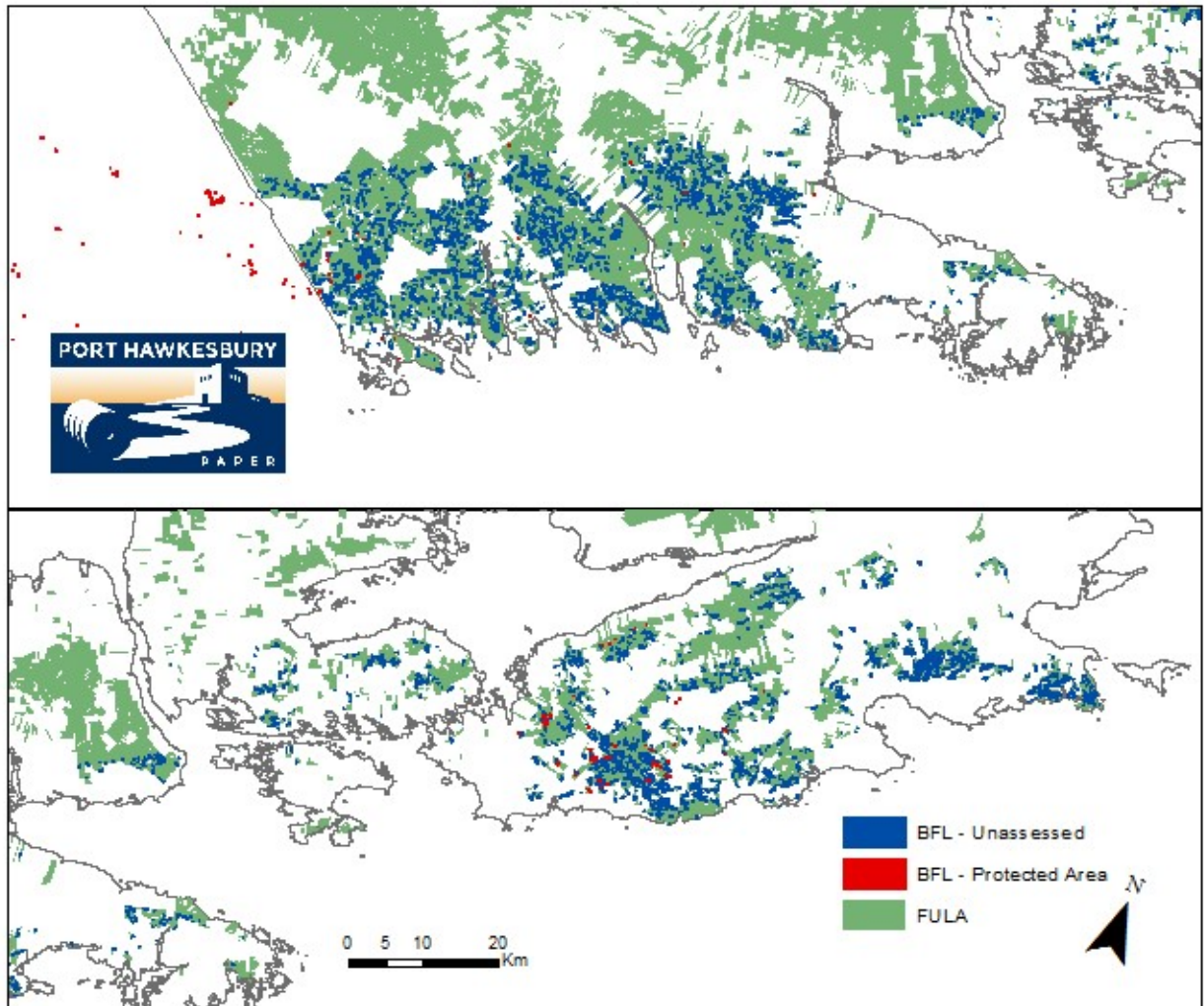

Figure 10 - Map of Boreal Felt Lichen Potential Habitat and Known Locations

# 11 LANDSCAPE LEVEL MANAGEMENT

## 11.1 Natural Disturbance Regimes

A fundamental landscape component of this long-term plan is the Natural Disturbance Regime (NDR) classification and management. There are 3 categories of NDR as follows according to the provincial Ecological Landscape Classification.

**Frequent:** Disturbances which result in the rapid mortality of an existing stand and the establishment of a new stand of relatively even age. The time interval between stand initiating events typically occurs more frequently than the longevity of the climax species that would occupy the site – therefore, evidence of gap dynamics and understory recruitment is usually absent. This regime results in the establishment and perpetuation of early to mid-successional vegetation types.

**Infrequent:** Stand initiating disturbances which result in the rapid mortality of an existing stand and the establishment of a new stand of relatively even-age, but the time interval between disturbance events is normally longer than the average longevity of the dominant species, allowing gap dynamics and understory recruitment to evolve and become evident (eventually creating uneven-aged stands). This regime generally leads to the establishment and/or perpetuation of mid to late successional vegetation types.

**Gap:** Stand initiating disturbances are rare. Instead, disturbances are characterized by gap and small patch mortality, followed by understory recruitment, resulting in stands with multiple age classes. This regime generally leads to the establishment and/or perpetuation of late successional vegetation types.

## 11.2 Integrated Pest Management

Since 1997, PHP (and previous mill owners) has maintained a non-herbicide use ‘policy’ on the managed leased lands. The NSDNRR initiates and manages the pesticide spray program on PHP’s Crown lease as needed.

PHP utilizes integrated pest management approaches across the FULA Crown lease. Monitoring plans, modeling forecasts, and tactical strategies in many cases are implemented in a joint partnership between PHP and NSDNRR.

Stand health and susceptibility to pests is managed on several different levels: Proactively, from both a long-term planning and operational standpoint, over-mature stands are targeted for harvesting first, and age class structures are managed to ensure proportionate area remains in all age classes. With the potential for an upcoming Spruce Budworm outbreak, the age class structure of the highlands is far less susceptible than the 1970’s when the age class structures were heavily mature and over-mature.

PHP assists DNR where possible in the surveying and monitoring of pest populations. The province reports on pheromone trap counts and, in the case of a Spruce Budworm epidemic, may request increased branch sampling to monitor L2 populations of the budworm.

PHP aids in the prediction of habitat susceptibility from pests through maintaining an updated inventory of forest cover information. Data pertaining to post treatment forest characteristics allows for accurate modeling predictions of forest susceptibility to pests

## 12 STRATEGIC CONSIDERATIONS AND ADJUSTMENTS

Following the release of “An Independent Review of Forest Practices in Nova Scotia”, the Nova Scotia government began steps to move towards a triad approach for forest management on Crown lands across the province. The modeling work conducted in 2021 between PHP and NSDNRR was the first effort to lay out a triad forest management system for PHP’s Crown license lands. This work was also completed to provide an updated annual sustainable harvest level for the re-negotiation of the FULA agreement between PHP and the Nova Scotia government. Strategic considerations, adjustments, and new forest management scenarios were developed for the 2021 analysis and are described in Appendix A – Timber Supply Analysis, and Appendix B – Data Package.

## 13 AGE CLASS DISTRIBUTION

The working land-base and high production areas are licensed Crown lands that contribute to wood supply objectives. A well distributed age class structure is favourable and indicates a diverse and healthy forest. The below figures illustrate the age class structure by forest state over the 100-year planning horizon in the ecological matrix and high production areas of the triad approach. Each graph or period represents a 5-year planning period. As evident by figure 14, the area occupied by older stands increases towards the end of the horizon in the ecological matrix. This effect is the result of implementing appropriate harvest treatments over time under the Silvicultural Guide for the Ecological Matrix. Figure 15 shows how the forest ages over time in the high production areas. As expected, the age class tightens up in the younger to mature class as time moves forward.

The legend for each graph shown below is represented by:

SHX – Selection Harvest Area

CTX – Commercial Thin Area

PCT – Pre-commercial Thin Area

PLX – Plantation Area

NRX – Natural Evenaged Regenerating

NAE – Natural Evenaged Unmanaged

NAU – Natural Unevenaged Unmanaged



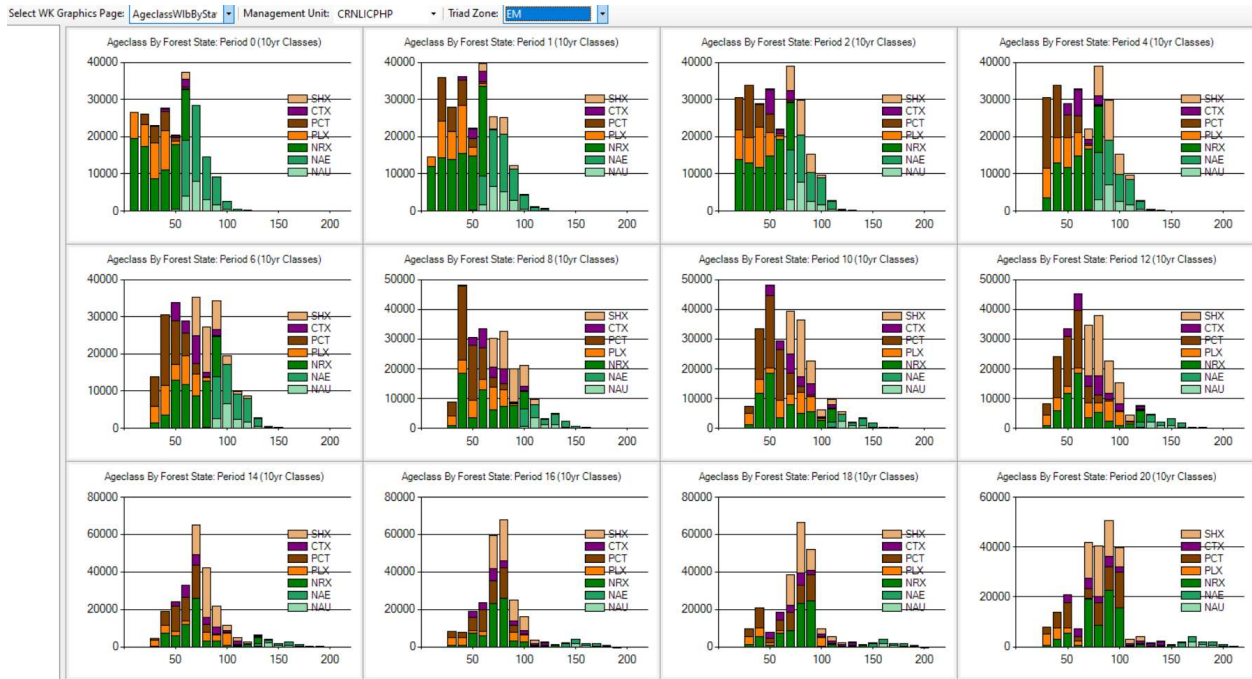

Figure 114 – 100-Year Planning Horizon Ageclass Distribution by Forest State in the Ecological Matrix

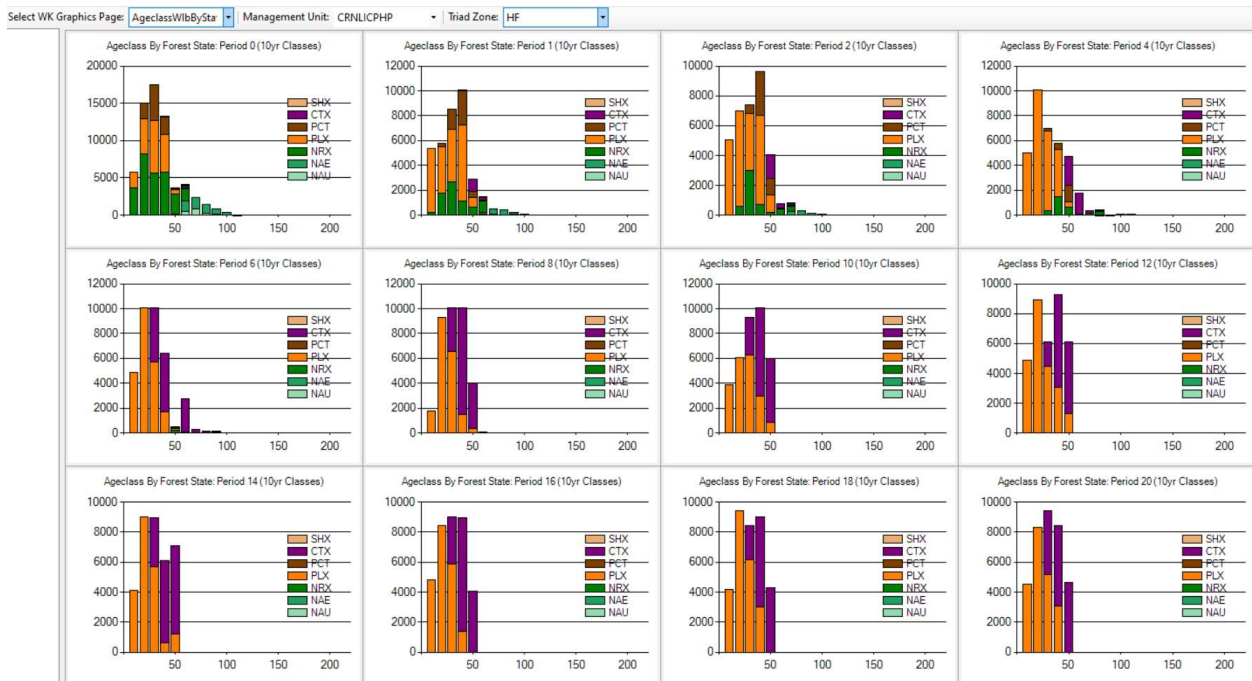

Figure 125 – 100-Year Planning Horizon Ageclass Distribution by Forest State in the High Production Areas



## 14 ECOLOGICAL-BASED MANAGEMENT

Ecosystem based management (EBM) was incorporated into the analysis using the same methodology as the 2016 Strategic Forest Analysis (SFA) Process. The Ecodistrict, Element, and Natural Disturbance Regime targets for forest composition indicators are set by the EBM technique (NDR). The goals for the frequent, infrequent, and gap NDRs for the mature development class indicator (i.e., stands > 40 years of age) were 40%, 60%, and 70%, respectively. For frequent, infrequent, and gap NDRs, the objectives for the late seral species composition were 33%, 40%, and 50%. Last but not least, the old forest/multi-aged objectives for frequent, infrequent, and gap NDRs were 8%, 16%, and 24% respectively. Beginning in year 50 of the forecast, this target lasts until year 100.

The distinction between stands that are or are not deemed mature in terms of structure has become less distinct with the introduction of new multi-aged / multi-cohort management prescriptions at varying retention levels within the ecological matrix. The analysis committee engaged with numerous departmental specialists to develop the rule-set for this study in the absence of any policy direction on maturity in these new prescriptions. This is not policy; rather, it is the team's projection of the policy's future course.

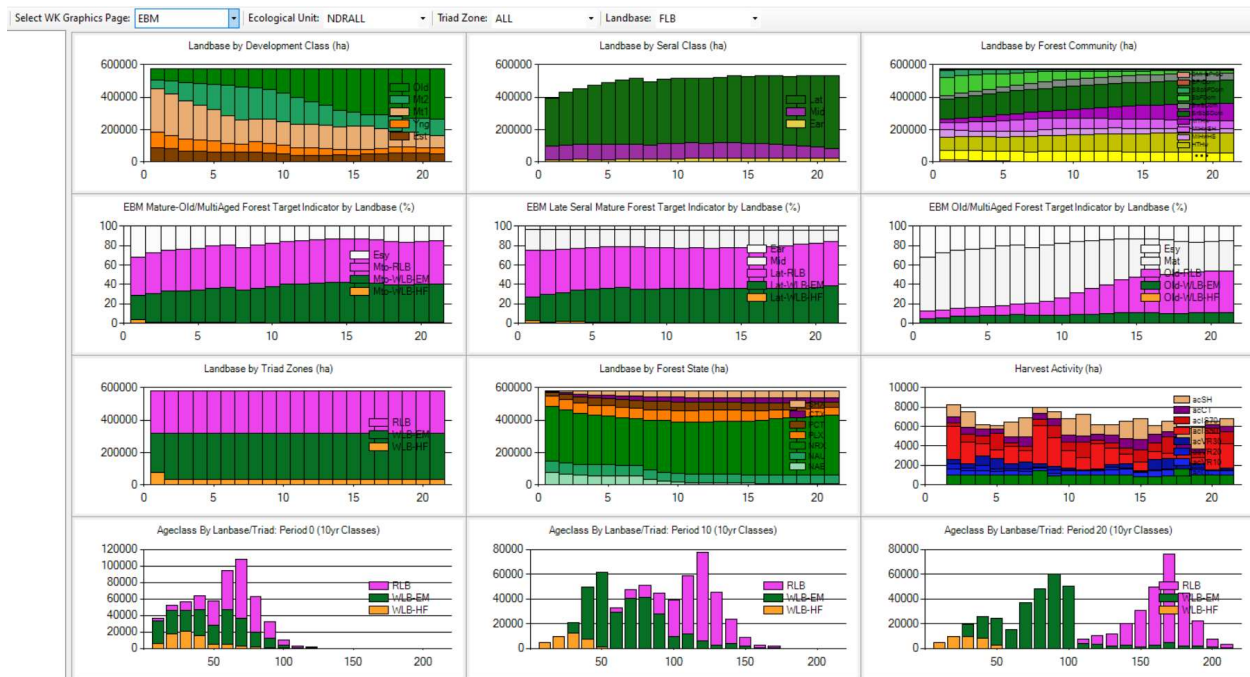

Figure 133 – Ecological-based Forest Management Outcomes in the Forested Land-base

## 15 *References*

- Allen, A.W., Jordan, P.A. and J. W. Terrell (1987). Habitat suitability index models: moose, Lake Superior region. U.S. Fish and Wildlife Service Biology Report 82(10.155), 47 pp.
- Banfield, A.W.F. (1987). The Mammals of Canada. Toronto University Press, Toronto, Ontario.
- Bellhouse, T. J. and B. J. Naylor (1997). Habitat relationships of wildlife in central Ontario. SSCS Technical Report No. 53. Ontario Ministry of Natural Resources, 58 pp.
- Bull, J.A. and J. Jr. Farrand (1998). National Audobon Society Field Guide to North American Birds. Alfred A. Knopf, New York, New York. 796 pp.
- Environment Canada (2000). Bicknell's Thrush, the Ultimate Thrush. Ottawa, Ontario.
- Erskine, A.J. (1992). Atlas of Breeding Birds of the Maritime Provinces. Nimbus Publishing, Halifax, Nova Scotia. 270 pp.
- Higgelke, P. E. H. L. MacLeod and F. Doyon (2000). Barred Owl (*Strix varia*). Prepared for Millar Western Forest Products' Biodiversity Assessment Project , 4 pp.
- Higgelke, P. E. H. L. MacLeod and F. Doyon (2000). Pileated Woodpecker (*Dryocopus pileatus*). Prepared for Millar Western Forest Products' Biodiversity Assessment Project, 15 pp.
- Kimmins, J.P. (1987). Forest Ecology. MacMillan Publishing Company, New York. 531 pp.
- Kirk, D. A. and B. J. Naylor (1996). Habitat requirements of the Pileated Woodpecker (*Dryocopus pileatus*) with special reference to Ontario. Ontario Ministry of Natural Resources, SCST Technical Report no. 46. 49 pp.
- Koehler, G. M. and J. D. Brittell (1990). Managing spruce-fir habitat for Lynx and Snowshoe Hare. Journal of Forestry: 88, 10-14.
- McGarigal, K. and J.D. Fraser (1984). The effect of forest stand age on owl distribution in southwestern Virginia. Journal of Wildlife Management: 48, 1393-1398.
- National Forest Strategy Coalition (2003). National Forest Strategy. Ottawa, Ontario. 26 pp.
- Natural Resources of Canada (2000). The State of Canada's Forests 1999-2000: forests in the new millennium. Canadian Forest Service. 120 pp.
- Natureserve (2001). Natureserve: an online encyclopedia of life [web application]. Version 1.2.
- Neily, P. D., E. Quigley, L. Benjamin, B. Stewart & T. Duke. (2003). Ecological land classification for Nova Scotia: volume 1 – mapping Nova Scotia's terrestrial ecosystems. Report DNR 2003-2. Nova Scotia Department of Natural Resources Renewable Resources Branch. 83 pp.

- Nova Scotia Department of Lands and Forests (1994). Impact of the 1974-1981 spruce budworm infestation on the forest of Cape Breton Island. Forest Research Report # 47.
- Nova Scotia Department of Natural Resources (1998). Managing Natural Resources on Crown Land: an overview of the eastern region. Halifax, Nova Scotia.
- Nova Scotia Department of Natural Resources (2007). Policy document: Nova Scotia Department of Natural Resources significant species and habitats project. 3 pp.
- Nova Scotia Department of Natural Resources (2008). Mapping Nova Scotia's Natural Disturbance Regimes. Report FOR 2008-5. Ecosystem Management Group, Forestry Division. 29 pp.
- Nova Scotia Department of Natural Resources (2016). Crown Lands Forest Model, Nova Scotia 2016 Strategic Forest Analysis, Technical Report. Forest Resource Analyst Group, Forestry Division. 160 pp.
- Nova Scotia Department of Natural Resources (2021). Eastern Crown Strategic-Level Forest Analysis. Forest Resource Analyst Group, Forestry Division. 60 pp.
- Ontario Ministry of Natural Resources (1998). A silvicultural guide for the Great Lakes - St. Lawrence conifer forest in Ontario. Ontario Ministry of Natural Resources. Queen's Printer for Ontario. Toronto, Ontario. 424 pp.
- Pendrel, B.A. (1991). Insect and disease caused losses of wood volume in forests of the Maritime provinces, 1982-1987. Forestry Canada, Maritime Region Information Report M-X-180E.
- Peterson, R.T. (1980). Peterson Field Guides: Eastern birds. Houghton Mifflin Company, Boston, Massachusetts. 384 pp.
- Stewart, B. and P. Neily. (2008). A procedural guide for ecological landscape analysis: an ecosystem based approach to landscape level planning in Nova Scotia. Nova Scotia Department of Natural Resources Report for 2008-2. 45 pp.
- Turner, M.G., Gardner, R.H., and R.V. O'Neill (2001). Landscape Ecology in Theory and Practice: Pattern and Process. New York, New York. 411 pp.

## *Appendix I      PHP Sustainable Forest Management Policy*

### **Mission**

The mission of the Woodlands Unit is to “provide a reliable, cost effective and high-quality supply of wood through the implementation of Sustainable Forest Management.

### **Vision**

The vision of Port Hawkesbury Paper LP Woodlands Unit is “that the forest resources, for which we have responsibility, will sustain healthy ecosystems and natural biodiversity, provide a continuous and expanding supply of valuable wood and conserve the forest characteristics of value to society, wildlife and the environment.”

### **Guiding Principles of SFM**

In order to “promote environmentally responsible, socially beneficial and economically viable management” of company forest resources, Port Hawkesbury Paper LP Woodlands Unit commits to:

1. Plan and conduct its forest operations to meet or be better than the requirements of all applicable regulations and legal obligations.
2. Conduct forest management practices consistent with and adhere to FSC® Principles and Criteria, and related FSC Policies and Standards.
3. Clearly establish and document long-term tenure and land use rights.
4. Recognize and respect indigenous people’s legal and customary rights and cooperate with local Aboriginal communities regarding conservation of forestlands.
5. Maintain or enhance long-term community relations and forest worker well-being. Provide opportunities for the public to receive education, exchange information and provide input to the identification of values, setting of objectives and selection of indicators, which form the basis of our forest management planning.
6. Manage for the conservation of a wide range of social, cultural, economic, and environmental benefits of forests that are consistent with our forest management objectives through the company’s High Conservation Value Forest (HCVF) Assessment and identified Forests of Exceptional Conservation Value.
7. Sustain long-term production of valuable wood by effectively using natural resources and ensuring forest renewal.
8. Implement planning processes and operating practices that conserve the biological diversity and ecological functions and integrity of the forest.

9. Prepare, implement and regularly update a documented forest management plan.
10. Monitor forest conditions, forest product yields, and the results of management activities, and strive for continual improvement through the implementation of science and technology developments, experience and research results.
11. Provide protected status for genuinely unique and representative natural landscapes and rare or endangered biotypes.
12. Develop and implement silviculture methods that complement or imitate natural forest processes to improve overall forest health and quality.
13. Protect the safety of employees and the public by implementation of the company Safety Policy.
14. Control and mitigate environmental impacts of the company's forest activities through implementation of the Woodlands Environmental Policy.
15. Maintain a certified Sustainable Forest Management System.
16. Consider other guidelines for SFM (i.e. the Criteria and Indicators of SFM of the Canadian Council of Forest Ministers (CCFM)) in determining forest management strategies and programs.

### **Guiding Principles of Wood Procurement**

In order to “promote environmentally responsible, socially beneficial and economically viable management” of all lands from which it receives wood, Port Hawkesbury Paper LP Woodlands Unit commits to:

1. Implementing and maintaining a certified Chain of Custody and Controlled Wood system to the Forest Stewardship Council® (FSC®) Standard, and a certified Chain of Custody system to the Sustainable Forestry Initiative® (SFI®) Standard and Programme for the Endorsement of Forest Certification (PEFC™) Standard.
2. Maintain internationally recognized Environmental Management System to ensure all wood originates from legal sources that are in compliance with the principles of sustainable forestry.
3. Support sustainable forest management and promote forest certification on all land used to supply the mill with fibre to protect, verify and communicate a wide range of economic, environmental and social values. Make publicly available non-proprietary results of third party certification audits and related Environmental Management System documentation (i.e. information pertaining to our FSC, SFI, and PEFC certification programs)
4. Efficiently harvest, transport and process wood to minimize waste of wood and resources.
5. Promote the sustainability of our wood sources by ethical purchasing practices and providing training and long-term partnerships to our suppliers.
6. Commit not to be directly or indirectly involved in the following unacceptable activities:

- a) Illegal logging or trade in illegal wood or forest products;
- b) Violation of traditional and human rights in forestry operations;
- c) Destruction of high conservation values in forestry operations;
- d) Significant conversion of forests to plantations or non-forest use;
- e) Introduction of genetically modified organisms in forestry operations;
- f) Violation of any of the ILO Core Conventions as defined in the ILO Declaration on Fundamental Principles and Rights at Work.)

## **Standard Practices for Sustainable Forest Management**

### **The Woodlands Unit of Port Hawkesbury Paper LP will:**

1. Develop long-term plans based on ecological landscape planning methods designed to provide a sustainable wood supply while ensuring conservation and restoration of components of the Acadian Forest ecosystem. Such plans promote ecological landscape level diversity, and forest product quality and quantity, while conserving biological and wildlife habitat diversity, mature forest habitat, old forests, natural softwood/hardwood/mixedwood forest community types.
2. On a five-year basis, use permanent sample plot information and accepted modeling procedures to develop or review the long-term forest management plan. The results of past management actions, the latest forest information and ecosystem-based management will be used to develop each subsequent plan, with the objective of continual improvement in our planning procedures. Through this adaptive management approach, we can ensure that we are managing our forests using the most accurate information, and the most current scientific theory.
3. Continue to cooperate with the provincial Department of Lands and Forestry through the Integrated Resource Management process to provide protected or conservation status for genuinely unique and representative natural landscapes, and rare or endangered biotypes.
4. Continue to provide participation opportunities for Aboriginal peoples with respect to their rights and interests in sustainable forest management issues.
5. Identify, map and manage special sites based on collaborative work with the Province of Nova Scotia and provincial environmental non-governmental organizations.
6. On Crown land areas licensed to the company, submit all silviculture and harvesting plans to government authorities for approval by forest and wildlife scientists prior to operations beginning. All operations will be inspected by government authorities during and at completion of activities.
7. Implement the requirements of the Forest Utilization License Agreement.
8. Plan and conduct all forest operations in accordance with the Wildlife Habitat and Watercourse Protection Regulations and Forest/Wildlife Guidelines for Nova Scotia, which include criteria for



stand level wildlife habitat elements to be retained (e.g., snags, mast trees, down woody debris, den trees, nest trees, etc.).

9. Utilize the silviculture system most appropriate to the ecodistrict and site. These can include full removal or partial cutting techniques for harvests, promotion of natural regeneration, planting, release spacing of young stands, maintenance or natural species diversity and encouragement or re-establishment of valuable shade tolerant species, such as red spruce, yellow birch and sugar maple. All forest practices will ensure efficient utilization of trees. Harvesting and other silviculture practices will be augmented to address aesthetics where necessary and appropriate.
10. Address management and protection of water bodies and riparian zones and implement Provincial BMP's during all phases of management activities including exclusion zones, shutdown procedures, and careful road construction. Mill inventories and procurement practices during adverse weather conditions will be guided by PHP's Adverse Weather Policy.
11. Protect and maintain forest and soil productivity and stability by wood harvesting machine tire/track standards, trail rutting restrictions, and logging slash distribution policies.
12. Protect forests from damaging agents from occurrences such as fire, invasive exotic and domestic pest plants, animals, insects and disease. The company does not use chemical pesticides.
13. Promote awareness and provide information on Port Hawkesbury Paper LP forest activities to employees and the public through tours and information programs. Community concerns about forest practices will be responded to in a sensitive and progressive manner as outlined in the Woodlands Environmental Management System (EMS) "concerns from interested persons" procedure. Forest worker well-being is ensured through implementation of the Port Hawkesbury Paper Safety policy.
14. Periodic broad-based public input into our forest management planning process will be implemented through the IRM public consultation process with the Department of Natural Resources. Ongoing public input will be through our Forest Advisory Committee established for the company's Woodlands Unit. We will manage and allow for public recreation where safe and appropriate.
15. Facilitate professional training of wood producers and train those staff employees and operators responsible for implementing BMP's to protect water quality. Promote sustainable forest management practices and provide assistance to private woodlot owners and other private wood producers through the implementation of section 6 of the Woodlands Environmental Policy and implementation of the Nova Scotia Forest Sustainability Regulations.
16. Support, through participation in the Nova Scotia Tree Improvement Working Group, appropriate research, testing, evaluation, and development of genetically improved trees. The company does

not use genetically modified organisms (GMO's) in its reforestation programs. Support other sustainable forest management research, science and technology initiatives as appropriate.

Approved By:

Dennis Boulet

Manager, Woodlands

Port Hawkesbury Paper LP

August 4, 2022

## ***Appendix II Environmental Policy - Woodlands***

It is the policy of Port Hawkesbury Paper LP to carry out operations in ways that do not endanger the environment. Sustaining a healthy environment will be an integral part of all company operations.

Our company forest resources will be managed for long-term sustainability and natural biodiversity while providing a sustainable harvest volume and conserving social and cultural values of the community. The company is committed to implementing its sustainable forest management mission, vision, and guiding principles.

**In maintaining an Environmental Management System the company, through its employees, shall:**

1. Commit to continual improvement of all aspects of our sustainable forest management system for company-managed lands through experience and forest research.
2. Set appropriate environmental objectives and targets, develop applicable action plans, review progress, and conduct periodical reviews and annual updates.
3. Commit to prevention of pollution, soil conservation, waste reduction, and promotion of applicable recycling in managing our environmental impacts.
4. Utilize long-term landscape ecosystem planning, appropriate silviculture systems, and operating practices that conserve biodiversity in managing our forest areas.
5. Provide appropriate training to company employees and contractors in the relevant environmental aspects of their work on company controlled lands.
6. Expect our private wood suppliers to comply with forest stewardship and environmental standards acceptable to Port Hawkesbury Paper LP.
7. Develop, maintain, and use Emergency Response Plans for environmental emergencies within the Woodlands Unit.
8. Meet or be better than all applicable regulations, legal obligations and other requirements to which Port Hawkesbury Paper LP subscribes.
9. Regularly report on our environmental performance and status to the public.

This Environmental Policy and our Environmental Management System shall be accessible, documented, implemented, maintained, reviewed and communicated to all persons working for or on the Woodlands Unit behalf.

## Appendix III Bio-Indicator Species

### Barred Owl (*Strix varia*)

The Barred Owl, is a large stocky owl (approx. 43-60cm in height), readily identified by its grey-brown body with cross-barring on the neck and breast, and streaks on the belly (Bull and Farrand 1998). It is one of the two common large owls that are permanent residents of temperate North America. It is a nocturnal species, and is a year round resident in Eastern Canada (Peterson 1980). The Maritimes provinces are close to this bird's northeast limit, and it is suspected that the scarcity of birds found in New Brunswick and eastern Nova Scotia may be due to avoidance of the more coniferous forests found here.

Although the Breeding Bird Survey distribution map shows very low numbers found in eastern Nova Scotia, the Atlas of Breeding Birds of the Maritimes shows higher numbers, with a number of confirmed breeding sites found in addition to probable and possible sightings. The population estimates derived from these sources is not completely accurate as they are primarily carried out through the daylight hours, when owls are typically least active. Current projects, such as the nocturnal owl survey, will help to establish a better estimate of the population base, and help with continued monitoring of the population. Presently however,

the breeding bird atlas estimates the total number of birds within Nova Scotia to be near 2 100 (+/- 300) in total.

Most of the nests reported in the breeding bird atlas of the Maritimes were found to be in nest boxes (Erskine 1992).

Considered one of the more common owls of the Maritimes it is suspected that its numbers were at their lowest levels early in the 20<sup>th</sup> century, with a slight increase since then. Currently, the Barred Owl is rated as a green species in Nova Scotia, which is a rank assigned to species that are not known to be, or not believed to be, at risk. The BBS trend data presented here are for Canada, rather than for the Atlantic Maritime Ecozone as it was the only information. The paucity of information is likely the result of the BBS taking place primarily during daylight hours, and not picking up many of the owls due to their largely nocturnal activity patterns.

The Barred Owl has been selected as a management indicator species in some national forests in the United States as well as selected forest management areas in Canada (McGarigal and Fraser 1984, Higgleke *et al.* 2000, Williams pers. comm.). This previously well-demonstrated use as an indicator species gave us further confidence that the Barred Owl would be a good indicator species which had the added benefit of providing consistency/comparison with other jurisdictions in North America. Its requirements for closed canopy mature and over-mature forest, and affinity for large diameter trees for

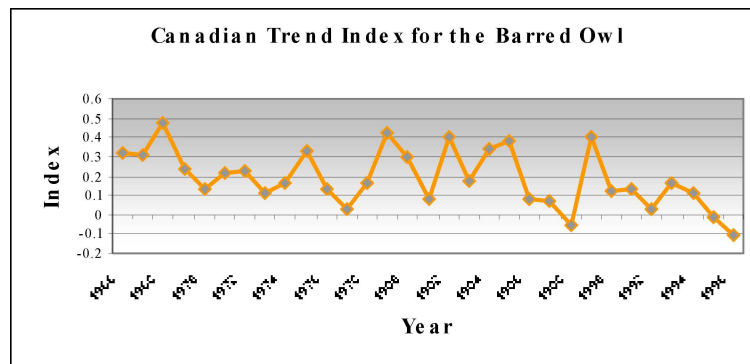

nesting make it a good candidate as a bio-indicator for the Uplands EPU, characterized by older, largely deciduous forest types.

### White-winged Crossbill (*Loxia leucoptera*)

The White-Winged Crossbill is a medium sized (15 – 17 cm) sparrow, which primarily inhabits conifer forests. It is quite easily recognized in the field by its characteristic crossed-tipped mandibles. Distinguishing it from the only other bird with this bill type, the Red Crossbill (*Loxia curvirostra*) are the two prominent white wing bars present on both the male and female birds. The white -winged crossbill breeds in the boreal forests from Alaska and northern Quebec south to Newfoundland and British Columbia and is a permanent resident here in Nova Scotia. Breeding in all areas is erratic, and is dependent on the seed crops of fir, spruce and larch, with the main breeding efforts in the Maritimes occurring January to April, and July to October (Erskine 1992).

According to the 1992 breeding birds census, there were approximately 31 000 (+/- 13 000) breeding pairs found in Nova Scotia. Due to the crossbills dependence on cone seed crop abundance, and the biannual fluctuations in cone crops, monitoring of this species will be restricted to a biannual basis. This will prevent the influence of naturally occurring, small-scale variations on the assessment of forecasted habitat availability. It is interesting to note at this point that the dramatic increase in the crossbill numbers in the Maritimes is a sharp contrast to what is occurring on a national level. The Canadian trend index shows the populations declining quite significantly.

We have identified the White Winged Crossbill as a good indicator since it occurs throughout Eastern Nova Scotia and is

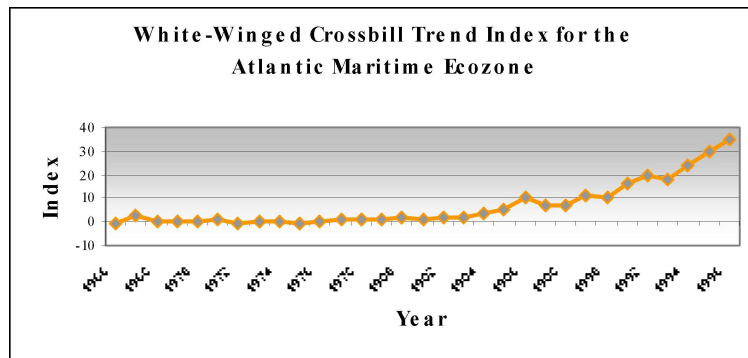

considered a habitat specialist, preferring older softwood forest stands with a healthy cone crop. This, in addition to the active monitoring the populations receive through the Breeding Bird Surveys and Christmas bird counts give PHP a good opportunity to model our forest management techniques to maintain suitable habitat. Currently, the White Winged Crossbill is ranked as a Green species in Nova Scotia.

### Black-backed Woodpecker (*Picoides articus*)

The Black-backed woodpecker is a robin-sized woodpecker (approx. 23cm), which is identified by its solid black back, white barred flanks and white below. The male displays a yellow crown, while the female has a solid black crown. This woodpecker, along with the three-toed woodpecker, is the most northerly of the woodpecker family, and has a distribution throughout the boreal range from Alaska

through to Labrador and Nova Scotia. It can also be found in the northern most United States, typically in the mountain regions of California and New England. Presence of either of these birds can be detected by the 'scaling' of bark from trees as they forage for burrowing insects and larvae.

Both birds are considered numerous throughout their range, however neither is commonly found (Bull and Farrand 1998). As it is not a commonly encountered species, it is worthy to note that neither the North American Breeding Bird Survey, nor the annual Christmas bird counts detect this species regularly (NatureServ 2001), and that the distribution map presented above should only be considered for the broadest-scale trend estimates.

In the Maritime Provinces, the Black-back is widely but thinly distributed throughout the conifer forests, and becomes more abundant further to the north (Erskine 1992). Due to their feeding preference, Black-backs are typically found in near proximity to older forests which are more susceptible to insect infestations. Nests in the Maritimes are often found in quite open areas, such as

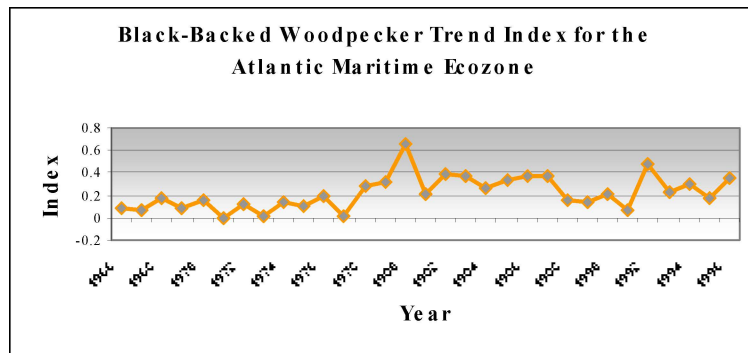

cutovers, open jack pine stands, and the edges of woodland gardens. The population is thought to have increased in this area since the period of European settlement, which removed much of the primeval hardwood and mixed wood, replacing it with spruce and fir (Erskine 1992). According to the Breeding Bird Census of 1992 there are approximately 1600 (+/- 200) nesting pairs found in Nova Scotia. The Department of Natural Resources has ranked this species as green for the province. The long term BBS trend index shows that the population has been relatively stable over the past 30 years, showing only a slight increase overall.

The Black-backed woodpecker has been reported locally throughout eastern mainland Nova Scotia, and its feeding and habitat requirements make it a good indicator species for mature, over-mature, and intermediate aged coniferous and wetland forest areas. Population levels appear to be linked to large-scale disturbance such as budworm infestations and fire. Salvage logging of post-disturbance regions can be detrimental to population abundance. However, proper management of these areas is likely to prevent any substantial impact to abundance. Erskine (1992) recognizes that management of forests for softwood forest products is likely to ensure a continuing place for Black-backs to breed. However, shorter rotation forest practices may reduce the time available for insect damage to weaken trees to the stages especially favoured by this woodpecker. Conversely, silviculture systems aimed at increasing the quality will increase the amount of suitable habitat in the future. As an indicator species, the Black-back will ensure appropriate silviculture systems are followed in the Eastern Mainland lowlands ecological planning unit.



## Bicknell's Thrush (*Catharus bicknelli*)

Until recently, the Bicknell's thrush was considered a subspecies of the Grey Cheeked Thrush. It is very similar in appearance and habitat, with subtle differences that are difficult to identify in the field. It is characterized as being approximately the size of a large sparrow, with olive-brown back, buffy throat, grey-to-white underparts with black spotted chin and flanks (Environment Canada 2000). Although very closely related, the Bicknell's thrush can be distinguished from the Grey-cheeked thrush by its size, as the Bicknell's is much smaller. Physically it can be distinguished by its longer yellow colour at the base of the bill, and chestnut colouring on the upper tail.

The breeding range of the Bicknell's thrush stretches from New York's Catskill Mountains north to the lower shore of the Gulf of St. Lawrence, and east to Cape Breton Island. It is a migratory bird, having a winter range restricted primarily to the Greater Antilles. Although this species is a neo-tropical migrant, and it spends a large proportion of its time in areas not under our forest management practices, we have included it as an indicator due to its listing as a Red species by the provincial Department of Natural Resources, and ongoing interest by the Canadian Wildlife Service and local groups. The breeding distribution map given below shows the distribution of the Grey-cheeked thrush, as one for the Bicknell's is not available from Gough at this time. It is modified to show the distribution of the Bicknell's thrush along the eastern portion of Canada and the United States (as discussed previously). Although trend information for this species is not currently available, continued interest in the species and future monitoring will help to establish a base from which we can work.

The sparse distribution of the Grey-cheeked thrush on this map is evidence of its more northerly range, above the limit of the Breeding Bird Survey area. The 1992 breeding bird atlas for the Maritimes notes that all species of Grey-cheeked thrush found in the Maritimes were of the *Bicknelli* subspecies (Erskine 1992), whereas this subspecies gained rank as a distinct species in 1995. From this account we can make the assumption that the grey-cheeked thrush counted and commented on is indeed the Bicknell's thrush.

The Bicknell's thrush is a bird that finds suitable habitat in montane forests dominated by stunted balsam fir and spruce at elevations ranging from 450 metres (Cape Breton Island) to more than 915 metres further to the south (Vermont). The Bicknell's also appear to use dense regenerating growth, and in Canada, it will make use of second growth industrial forest where elevations and dense growth characteristics are appropriate. Much of the breeding biology and status is unknown for this thrush throughout its breeding range, but the populations are thought to be patchy, having a small breeding population widely dispersed. Although this could create genetic bottlenecks, it may also likely protect the species from widespread extinction. Currently the species is ranked as Red by the Nova Scotia Department of Natural Resources, and has been listed as Vulnerable by Committee on the Status of Endangered Wildlife in Canada (COSEWIC)

This species is a good candidate as an indicator species as it is a resident of the unique Taiga ecosystem found in the Cape Breton Highlands. This ecological planning unit is characterized by short, dense coniferous and Krummholtz habitat, and is primarily seedling, sapling and intermediate age classes. Although forest practices are not the only factor threatening the long-term viability of the populations, we think it is important to include this thrush in our long term planning and modelling procedures to ensure this dense forest structure is maintained.

### **Pileated Woodpecker (*Dryocopus pileatus*)**

The Pileated woodpecker is probably one of the most obvious and showy members of the woodpecker family in Canada. The largest of the woodpeckers in North America, (averaging 42 cm in height) it is often heard rather than seen. Its upper surface is black or dark grey in colour, with a white patch on the underside of its wings. Its red crest and white line around its neck are obvious to those who see one. Evidence of this woodpecker is noted by the large oval cavities it hollows out in trees and snags as it feeds or nests. These cavities created by the Pileated woodpecker serve an important ecological role as they are often used by numerous other bird and mammal species once the woodpecker has moved on. Other cavity nesting or roosting species that are dependent on these holes include the Boreal Owl, Screech Owl, Saw-Whet Owl, Wood Duck, American Kestrel, Common Flicker, Northern Flying Squirrel, and American Marten. There are approximately 32 other species that depend on these cavities for their own success (Higgelke *et al.* 2000). Additionally, the woodpecker is thought to have a significant role in the control of insect outbreaks (Kirk and Naylor 1996).

This large bird is found widely throughout forested regions of North America and is a permanent resident of Nova Scotia, where it is currently ranked by the provincial Department of Natural Resources as a 'Green' species. Due to its size, feeding and nesting characteristics, this bird is restricted to extensive forest areas with old, large diameter trees. In the Maritimes pileated woodpecker distribution seems focused on forest stands dominated by deciduous trees (Erskine 1992). This trend is likely explained by the fact that the trees of largest diameter are typically remnant hardwood. The breeding bird atlas for the Maritime provinces estimates the breeding population of pileated woodpeckers in Nova Scotia to be approximately 2 800 (+/- 1 200) pairs. This is thought to be a decline in the numbers found in the area since European settlement, and the subsequent clearing of forested land. The BBS trend index shows a relatively stable population over the past 30 years, with some dramatic changes in the past number of years. These may be a result of varied sampling effort, or seasonal differences in the breeding effort. It is important to keep in mind the long-term population trend, which does indicate an overall decline.

From a management perspective, selection cuts and shelterwood preparatory or seedling cuts do not appear to significantly affect habitat suitability (OMNR 1998). However, clearcuts and shelterwood removal cuts produce habitat that will not be suitable for nesting for 40 – 80 years. Cavity trees, snags and

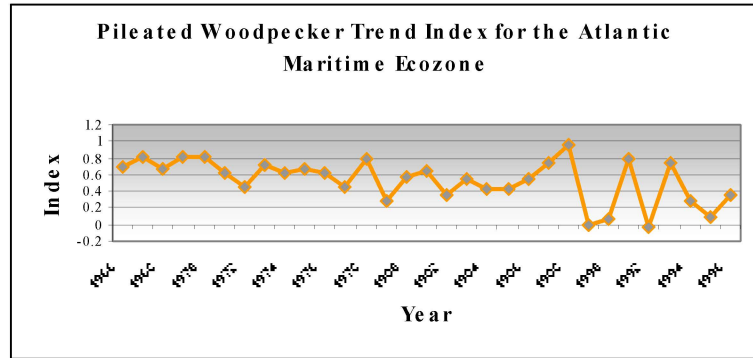

downed woody debris are an important component of pileated woodpecker habitat, providing for nest, roost, and/or feeding sites (Kirk and Naylor 1996). These essential features should be provided when stand level guidelines are applied. Long-term planning strategies and the constant implementation of adaptive management techniques at both the stand and landscape level are required to ensure that the habitat requirements of this bird are met into the future.

The Pileated Woodpecker makes an ideal indicator species as it has very specific habitat requirements, which cannot be met through artificial means (i.e. it is not readily attracted to nest boxes). It is also a key species where the long-term presence directly impacts the reproductive success and survival of many other species dependent on the cavities it creates. The most notable area for confirmed breeding of the Pileated in Eastern Nova Scotia is throughout the Northumberland Shore EPU, where intolerant hardwood and mixed wood forest types predominate. Using the Pileated as an indicator for this region maintains a level of consistency since it has been chosen as an indicator, or management species by almost all provincial natural resource planning agencies in Canada (Kirk and Naylor 1996)